













RIVKLE®











Fasteners for sheet metal and plastic,
offering a simple solution
even for single-sided installation.

BÖLLHOFF

RIVKLE® Blind rivet nuts and studs, our product portfolio

		Steel	Stainless steel	Aluminium	Sizes	Flat head	Countersunk head	Extra-small countersunk head	Open	Closed	Round body plain	Round body knurled	Hexagonal body	Part hexagonal body	Page
	RIVKLE® plus	●			M4 to M10	●			●			●			15
	RIVKLE® plus	●			M4 to M8	●			●					●	15
	RIVKLE® plus	●			M4 to M10			●	●			●			15
	RIVKLE® plus	●			M4 to M8			●	●					●	15
	RIVKLE®	●			M3 to M14	●			●	●	●				16
	RIVKLE®	●			M3 to M14		●		●	●	●				17
	RIVKLE®	●			M3 to M10	●			●	●		●			18
	RIVKLE®	●			M3 to M10		●		●	●		●			19
	RIVKLE®	●			M4 to M12	●			●	●			●		20
	RIVKLE®	●			M3 to M8			●	●		●				21
	RIVKLE®	●			M3 to M12			●	●	●		●			22

RIVKLE® Blind rivet nuts and studs, our product portfolio

		Steel	Stainless steel	Aluminium	Sizes	Flat head	Countersunk head	Extra-small countersunk head	Open	Closed	Round body plain	Round body knurled	Hexagonal body	Part hexagonal body	Page
	RIVKLE®	●			M4 to M12			●	●	●			●		23
	RIVKLE®	●			M4 to M8			●	●					●	23
	RIVKLE® with optimised head projection	●			M4 to M12			●	●				●		24
	RIVKLE®		●		M4 to M10	●			●		●				25
	RIVKLE®		●		M4 to M10		●		●		●				26
	RIVKLE®		●		M3 to M12	●			●	●		●			27
	RIVKLE®		●		M3 to M12		●		●	●		●			28
	RIVKLE®		●		M3 to M8			●	●		●				29
	RIVKLE®		●		M3 to M12			●	●	●		●			30
	RIVKLE®		●		M4 to M8	●			●					●	31
	RIVKLE®		●		M4 to M10			●	●					●	32

RIVKLE® Blind rivet nuts and studs, our product portfolio

		Steel	Stainless Steel	Aluminium	Sizes	Flat head	Countersunk head	Extra-small countersunk head	Open	Closed	Round body plain	Round body knurled	Hexagonal body	Part hexagonal body	Page
	RIVKLE®		●		M4 to M6			●		●				●	32
	RIVKLE®		●		M4 to M8			●	●					●	33
	RIVKLE®		●		M4 to M6			●		●				●	33
	RIVKLE®			●	M3 to M12	●			●	●	●				34
	RIVKLE®			●	M3 to M12		●		●	●	●				35
	RIVKLE® HRT	RIVKLE® HRT blind rivet nuts with high resistance thread													36 - 39
	RIVKLE® PN	RIVKLE® PN Blind rivet nuts with slotted shank for ultimate pull-out force values													40 - 41
	RIVKLE® Elastic	RIVKLE® Elastic – Fasteners for vibrating components													42 - 48
	RIVKLE® Standard blind rivet studs	RIVKLE® Standard blind rivet studs													49
	RIVKLE® Special designs	RIVKLE® Special designs of blind rivet studs													50
	RIVKLE® Special designs	RIVKLE® Special designs of blind rivet nuts													51 - 52

Our product portfolio of RIVKLE® Setting tools and Setting machines

			Page
	RIVKLE® Setting tools	Hand-operated setting tool for limited production volumes, Typ S and Z 305	53
	RIVKLE® Setting tools	Hand and Battery operated setting tools for limited and medium production volumes, ZH 510 and E 308	54
	RIVKLE® Setting tools	Hydraulic / pneumatic setting tools for medium and high production volumes, P 2005 and P 2007	55
	RIVKLE® Setting machines	Hydraulic / pneumatic setting tools for processing of RIVKLE® PN blind rivet nuts P 2001 PN	56
	RIVKLE® Setting machines	RIVKLE® Setting machine, EPK C and SAC 310 Accessories for P 2005, P 2007 and EPK C	57
	RIVKLE® Setting machines	RIVKLE® Installation machine, automatic setting head, HSA 803 and CFA 803	58
	RIVKLE®	Advice for optimum assembly	11 - 13
	RIVKLE®	Examples of where our products can be found	6
	RIVKLE®	Advantages to you from using RIVKLE® and example of applications	7
	RIVKLE®	How to select the correct RIVKLE®	8 - 10
	RIVKLE®	RIVKLE® plus – Top class steel blind rivet nuts	14 - 15

Examples of where our products can be found

Our fastening and assembly technology finds uses in a diverse range of applications:

- Cars and motorcycles, bumpers, safety belts, airbags etc.
- Commercial vehicles, trailers, fire engines
- Electrical and electronic products, safety cabinets
- Food processing industry, ovens, extraction hoods, fast food counters
- Heating and ventilation plant, air conditioning units and heating boilers etc.
- Office furniture, cash registers, chairs, desks, photocopiers
- Building and civil engineering, street furniture, conservatories
- In leisure areas, climbing walls, yachts, swimming pools etc.

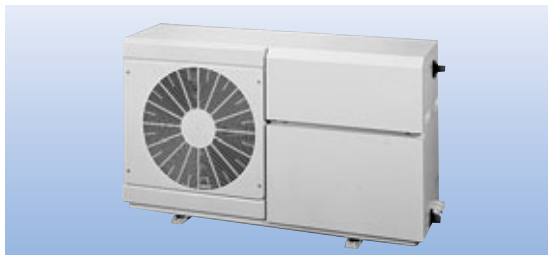

RIVKLE® Advantages

RIVKLE® blind rivets and studs are the most versatile solution for adding a load carrying internal or external thread to thin-walled workpieces.

They can be installed into plastic or even ceramic components and into all metals.

The blind i.e. one-sided setting technique means that RIVKLE® blind rivet nuts and studs are often the only fastener solution for hollow sections, housings or where access is limited to one side of a component.

No additional finishing is required after setting, even with coated or painted components. Thus RIVKLE® blind rivet nuts and studs can be fitted at any stage in the production process, making their use extremely flexible.

Unlike welded captive nuts, RIVKLE® blind rivet nuts and studs do not subject the components to the damaging effects of high temperatures. The installer is safe as no fumes or gasses are produced and there is no risk of fire.

The short time it takes to set RIVKLE® and their low installation costs, mean that RIVKLE® blind rivet nuts and studs have clear economic advantages compared with all other types of fasteners:

- Cumbersome presses or pliers are not required.
- RIVKLE® blind rivet nuts and studs connections can be safely made and remade without loss of performance.
- For manufacturers who wish to supply components with fitted threaded connections, RIVKLE® blind rivet nuts and studs offer advantages without risks.

RIVKLE® Examples of applications

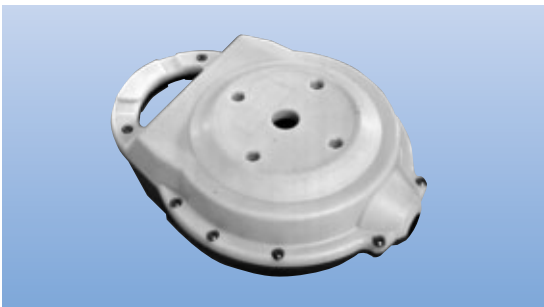

Cable reel
RIVKLE®*plus* M4,
steel, flat head,
knurled body.

Advantage: The knurled body gives high turning resistance.



Desk frame
RIVKLE® M8, steel,
flat head, round body.

Advantage: Blind assembly from one side only.

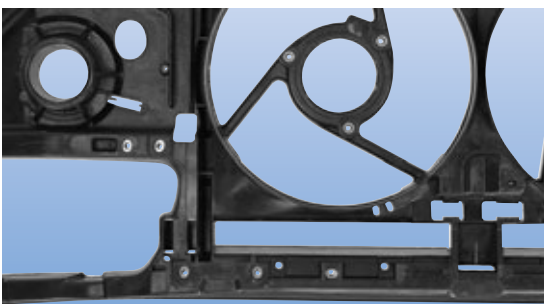

Plastic front grille
RIVKLE® M6, steel, round
body underhead with
knurl, open end.

Advantage: Extra-large flat head gives increased strength compared to standard RIVKLE®.

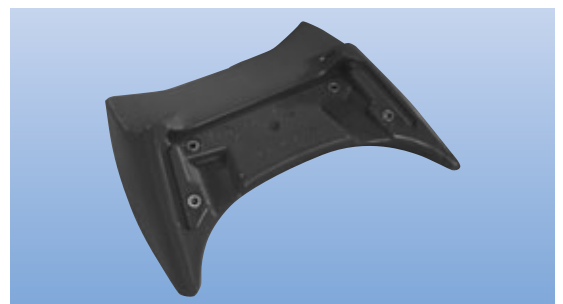

Motor scooter spoiler
RIVKLE® M5, steel, flat
head, knurled body.

Advantage: Extra-large flat head gives increased strength compared to standard RIVKLE®.

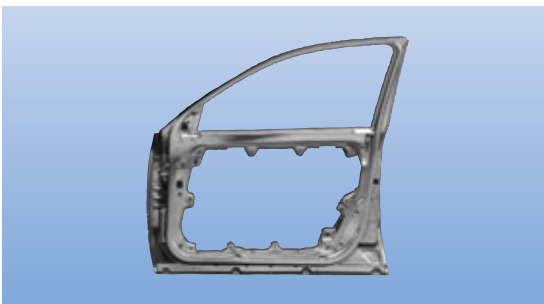

**Car door (interior)
galvanised steel**
RIVKLE® M6, steel, extra-
small head, hexagonal
body, open end.

Advantage: Allows fully automatic assembly.

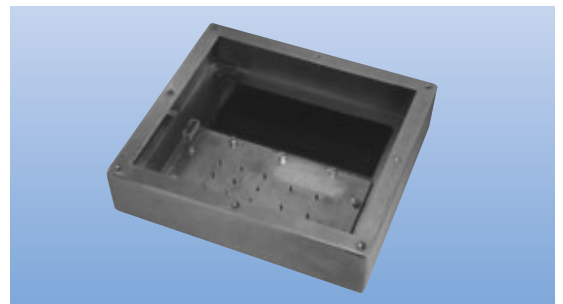

Weighing machine base
RIVKLE® M5, stainless
steel, small hexagonal
head, closed end.

Advantage: Splash-proof fastening.

RIVKLE® Selection criteria for blind rivet nuts

Glossary of technical terms

■ **Head**

The part of the RIVKLE® blind rivet nut in contact with the top surface of the workpiece.

■ **Body**

The part of the RIVKLE® blind rivet nut below the head.

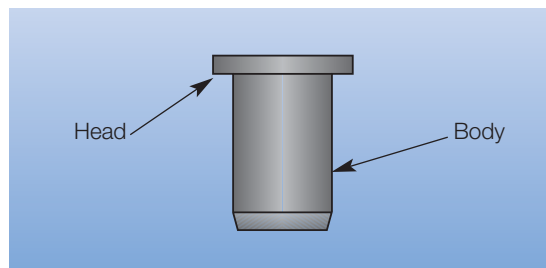

■ **Clamp thickness**

The total thickness of material made up of layers from one or more workpieces into which the RIVKLE® blind rivet nut is installed.

■ **Grip range**

The thickness of material must be between the minimum and the maximum values for which the RIVKLE® blind rivet nut was designed (the grip range).

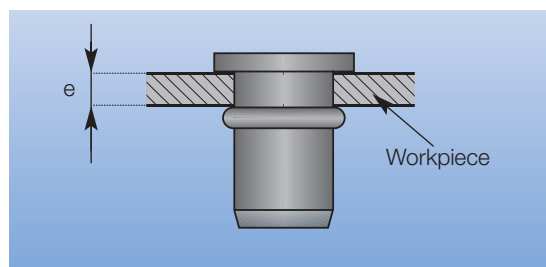

■ **Hole dimensions**

Given as diameter d for cylindrical holes and the across the flats dimension h for hexagonal holes.

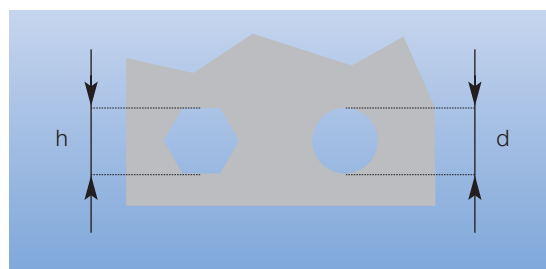

■ **Blind rivet nut materials**

RIVKLE® blind rivet nuts are manufactured from steel, stainless steel or aluminium. The materials we use have good deformability properties and a high resistance to turning in the upset area. Standard stainless steel RIVKLE® blind rivet nuts and studs are made from A1 or A2 austenitic steel containing 18% chromium and 10% nickel.

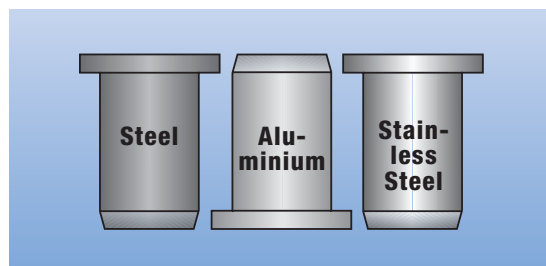

The advantages:

Steel = suitable for general use

Aluminium = low weight, corrosion resistant

Stainless steel = resistant to corrosion and temperature

■ **Mandrel and nosepiece**

Mandrel: The threaded stud on to which the RIVKLE® blind rivet nut is completely threaded.

Nosepiece: The part of the setting tool that is in contact with the RIVKLE® blind rivet nut head during the setting process.

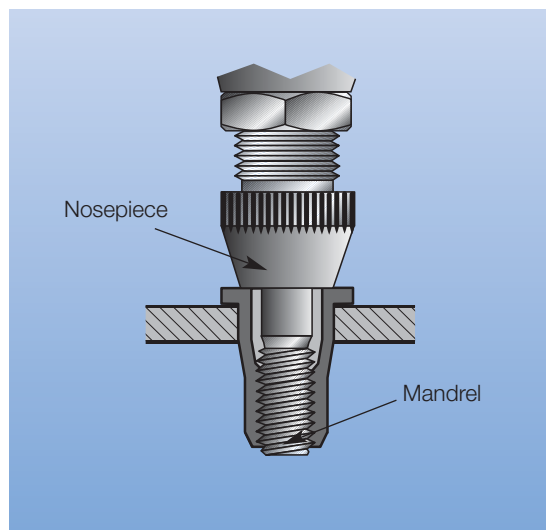

RIVKLE® Selection criteria for blind rivet nuts

Selecting the head

■ **Flat head**

This versatile head type is the one most commonly used in industry.

The arrow and V should point at the line between B and A, not at the gap created by deep-drawing. The idea is to demonstrate that the gap between B and A can be reduced to zero by deep-drawing.

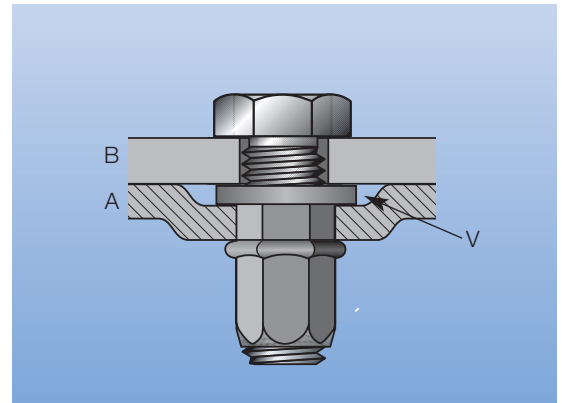

■ **Extra-small countersunk head**

This head type is used where the gap V is required to be small or zero.

V can be reduced to zero by:

- Using a collar to punch a slight depression in the parent material A
- By a slight countersinking of A
 - With malleable material the gap V is automatically eliminated.

Extra-small countersunk heads are an improved alternative to countersunk heads as they do not require the hole to be countersunk. However, they should not be used if:

- The hole is out of tolerance
- The parent material is malleable (as this could cause the head to pull through)
- The screw exerts a lateral moment on the RIVKLE® blind rivet nut.

RIVKLE® blind rivet nuts with extra-small countersunk heads are installed using setting tools with standard nosepieces.

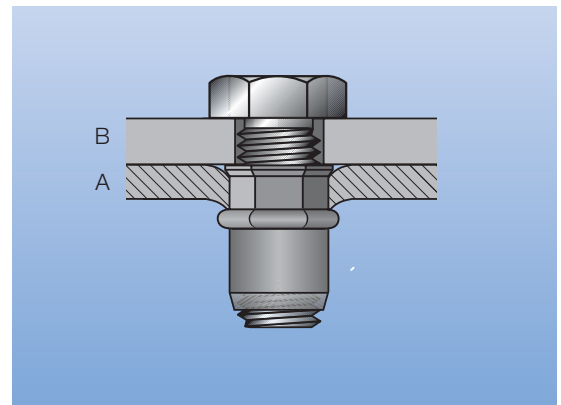
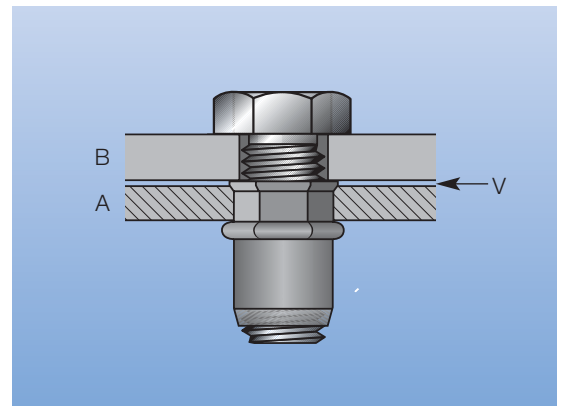

■ **Countersunk head**

Countersunk heads generally require countersinking of the parent material. Therefore a countersunk head is used where the gap V is required to be negligible but an extra-small countersunk head cannot be used.

We recommend that the countersinking (f) is made slightly shallower than the RIVKLE® countersunk head so that the head projects slightly beyond the surface of the supporting part A and thus makes as much contact as possible with the attached part B ($V > 0$) (detailed information on dimension (f) can be found on relating pages).

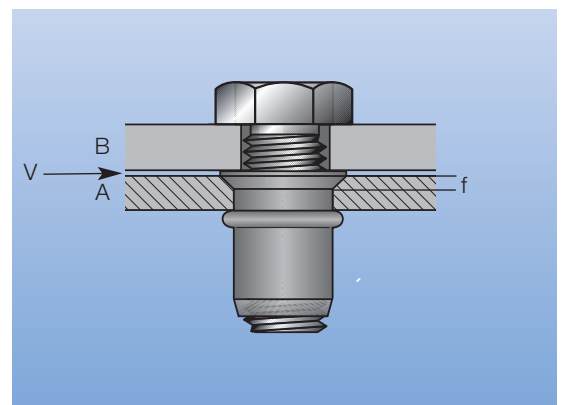

RIVKLE® Selection criteria for blind rivet nuts

Selecting the body

■ Hexagonal body

Using a hexagonal body in a hexagonal hole ensures the RIVKLE® blind rivet nut has the best resistance to over-torque turning.

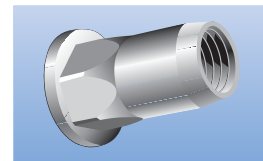

■ Round body, knurled or plain

For use where a hexagonal hole is not possible.

The knurled version is preferred to the smooth, particularly for use in plastic or soft materials (aluminium, PA, SMC etc.).

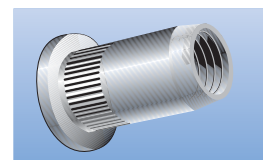

■ Open end

This is the most common option due to its compact form and the free choice of screw length.

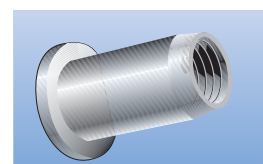

■ Closed end

For all uses where no liquid is to be allowed to pass between the screw and the RIVKLE® blind rivet nut. To form a pressure-tight seal between the blind rivet nut and the workpiece we manufacture RIVKLE® blind rivet nuts with a seal on the body side (see example on page 52).

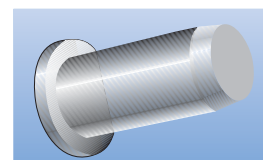

Selecting RIVKLE® blind rivet nuts and studs to suit your component

Measure the thickness of the parent material. Check that this thickness is within the RIVKLE® grip range (minimum – maximum).

If you have a choice between two RIVKLE® blind rivet nuts in the allowable tolerance range:

- Select the shorter RIVKLE® if the workpiece is hard. Use a 2330 706 0230 rather than a 2330 706 0255 for a material thickness of 3 mm.
- Select the longer RIVKLE® if the workpiece is soft. Use a 2330 706 0255 rather than a 2330 706 0230 for a material thickness of 3 mm.
- A relatively wide upset area is required for plastic workpieces and soft parent materials (aluminium) to achieve a high mechanical strength. Please contact us about this.

Surface treatment

All RIVKLE® steel blind rivet nuts and studs are zinc plated. The standard supplied surface treatment is 8µ zinc plated, yellow passivated. Other surface treatments are available on request for different corrosion resistance requirements

Selecting the material

Standard RIVKLE® are supplied in steel, aluminium and stainless steel. The choice of material depends on the strength of the RIVKLE® blind rivet nut and stud (see table page 12) and the required corrosion resistance of the completed end product. Our standard products manufactured from stainless steel are suitable for use in some catering and food processing industries. We would be pleased to provide you with further information on stainless steel or brass RIVKLE® blind rivet nuts or about corrosion resistance.

RIVKLE® Advice for optimum assembly

Before setting

- Hole diameter: Hole diameter requirements should be taken from the appropriate product table. The surfaces in the grip range should be parallel ± 0.05 .
- If possible use the preferred hexagonal or knurled RIVKLE® and always:
 - Install the RIVKLE® blind rivet nuts and studs in accordance with our recommendations (stroke S),
 - Ensure that the parts to be joined cannot rotate with respect to one another and that the gap between the elements to be riveted together is not too large.

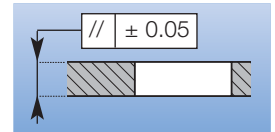

Setting

- We recommend that you use the spin-pull-spin setting technique. With this technique, the RIVKLE® blind nut or stud is threaded (spun) on to the mandrel, inserted into the hole and then pulled back (without rotation) to upset the rivet nut body. Finally the mandrel is spun off.

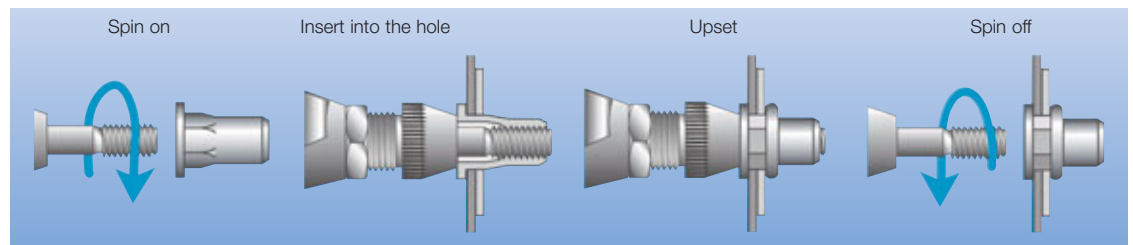

Our range of setting tools can be found on pages 53 to 58.

The P 2007 and EPK C setting tools have a pressure monitoring system, which is very useful for components with varying thicknesses (guarantees consistent setting).

Important: Setting several RIVKLE® at the same time can be done using a press. However, we advise you to contact us in advance about this. We would not recommend that you use mechanical screw drivers or spanners for blind riveting as they can damage the surface of the thread and thus have a detrimental effect on your connection.

Adjusting the stroke

- The product tables from page 15 onwards contain the setting stroke values recommended for optimum setting of each type of RIVKLE® blind rivet nut, e.g.:
RIVKLE® 2330 706 0230, P. 15, $S = 5 - e$, i.e. for a material thickness of $e = 2$ mm the RIVKLE® stroke S is adjusted to $S = 5 - 2 = 3$ mm.
- Note: The stroke is measured on the RIVKLE® (the difference in length before and after setting) and not on the tool. We recommend that you carry out a trial assembly before starting series production.

After setting

■ **Maximum dimension of the crimping flange (w)**

This applies to RIVKLE®plus and RIVKLE® blind rivet nuts and studs with the exception of the extra-small countersunk heads type 3430 1, 3430 8 and 3432 1.

Size RIVKLE®	M3	M4	M5	M6	M8	M10	M12
Max. crimping flange dimension (mm)	6.8	8.6	10.1	13.0	15.0	18.0	22.4

■ **Axial dimensions after setting**

The tables show indicative values of the projecting body length L_2 after installation.

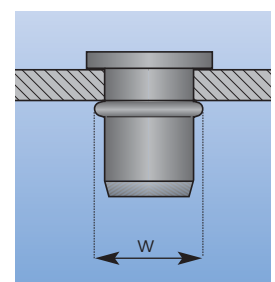

RIVKLE® Advice for optimum assembly

Selecting the mating screws

RIVKLE® internal threads are manufactured to the most common industrial tolerances (6H, in accordance with ISO 68). They are designed for use with most commercially available screws, i.e. including the most commonly used screw tolerance 6g.

RIVKLE® blind rivet nuts and studs, crimping torque

RIVKLE® can be used with all the screw types shown in the table below providing the maximum crimping torque (in Nm) is not exceeded.

Size RIVKLE®	Steel/ stainless steel	Aluminium
M3	1.2	0.7
M4	3	2
M5	6	4
M6	10	6
M8	24	15
M10	48	27
M12	82	45

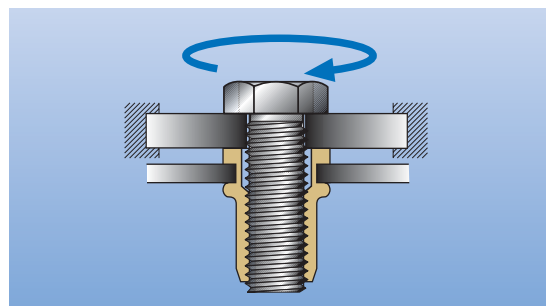

Note: For steel and stainless steel RIVKLE® from size M 3 up to and including M 10 these torques correspond to grade 8.8 screws.

Screw length

■ **In a RIVKLE® with an open end body**

The screw must project at least one thread length beyond the RIVKLE® open end.

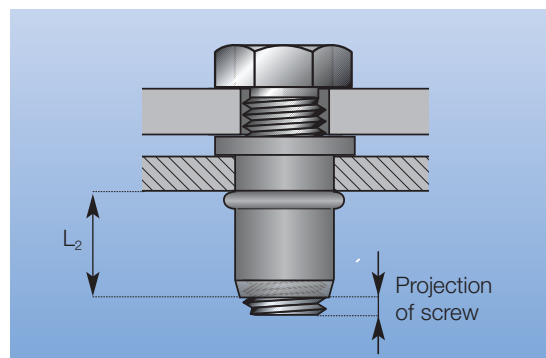

■ **In a RIVKLE® with a closed end body**

To calculate the maximum shaft length of the screw (Pmax.) for use in a closed end RIVKLE®, first determine the length L₂ of the corresponding open end RIVKLE®.

Then $P_{max.} = L_2 + e + E + X$

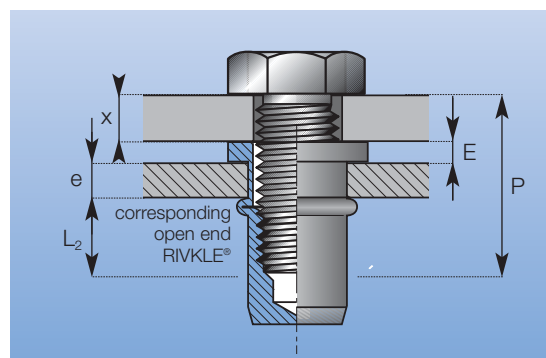

Hole in the attached part

The recommended diameter d₂ of the hole in the attached part is equal to the screw diameter multiplied by factor 1.1.

If countersunk or flat heads are used for a multiple RIVKLE® blind rivet nut installation in one workpiece, then if necessary this value should be altered to achieve equal spacing.

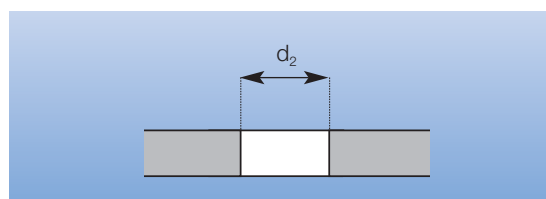

RIVKLE® Advice for optimum assembly

Thread lubricant

For the installation of large numbers of RIVKLE®, and in particular when using stainless steel components, to obtain the best connection every time, we recommend that the mandrel is lubricated before installation starts and after that at regular intervals.

Mechanical characteristics of RIVKLE® internal and external threads

■ **Axial proof load**

Size	RIVKLE® blind rivet nut steel & stainl. steel	RIVKLE® blind rivet nut aluminium	RIVKLE® blind rivet stud steel
M3	4 000	2 500	/
M4	6 800	4 000	/
M5	10 000	5 500	8 100
M6	15 000	8 300	11 500
M8	27 000	13 000	21 000
M10	37 000	20 000	/
M12	54 000	28 000	/

Unit: N

■ **Ideal setting temperature:** -30 to +80 °C.

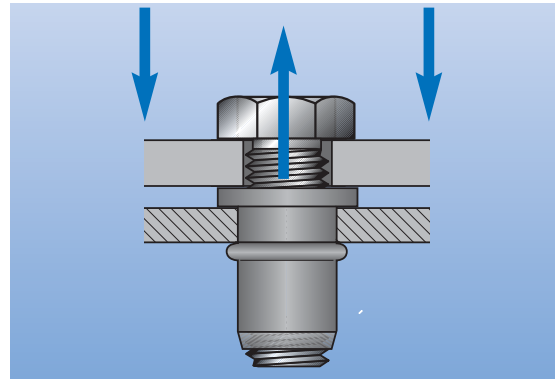

Special applications

■ **Function of high resistance thread**

For security-relevant components and parts that require high mechanical features, High Resistance Threads are provided by RIVKLE® HRT. Screws of grade 12.9 can be used for RIVKLE® HRT made of steel and screws of grade 8.8. can be used for RIVKLE® HRT made of aluminium.
(see page 36–39)



■ **Rivet function**

In addition to acting as blind nuts or studs, RIVKLE® can also be used to rivet two parts together and provide a threaded mounting for a third.

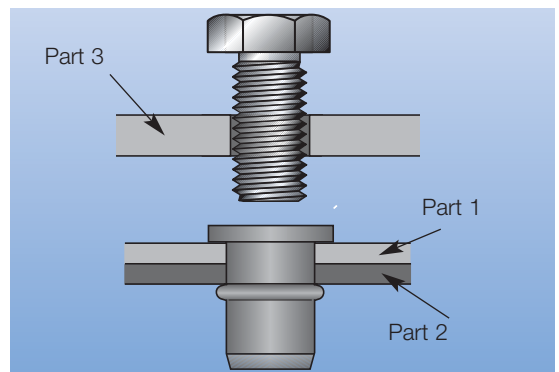

■ **Rear strengthened wall**

RIVKLE® blind rivet nuts and studs can be installed blind into walls with rear foam strengthening.

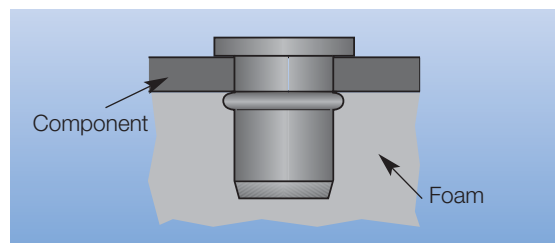

RIVKLE® plus top class steel blind rivet nuts

■ **Top class simplicity.**

Our range of 20 RIVKLE® plus covers 80 % of all your requirements for RIVKLE® steel blind rivet nuts. RIVKLE® plus speeds up product selection, simplifies ordering and stock control.



■ **Top class availability.**

All products in the RIVKLE® plus range are available immediately from stock.

■ **Top class connection efficiency.**

■ **RIVKLE® plus blind rivet nuts with knurled round bodies.**

The knurls provide additional security and resistance to turning for a RIVKLE® blind rivet nut in a cylindrical hole. Tests have shown that knurled RIVKLE® blind rivet nuts perform better than plain RIVKLE® blind rivet nuts even in hard parent material.



■ **RIVKLE® plus blind rivet nuts with part-hexagonal bodies.**

Being hexagonal over only part of the body, a spanner cannot be attached to mistakenly loosen the RIVKLE® blind rivet nut after installation (this could damage the connected component). This is important for applications in which regular maintenance is carried out for the whole of the service life of the product.



■ **Top class quality.**

RIVKLE® plus carries the Böllhoff logo, signifying that it is a high quality product.



RIVKLE® plus top class steel blind rivet nuts

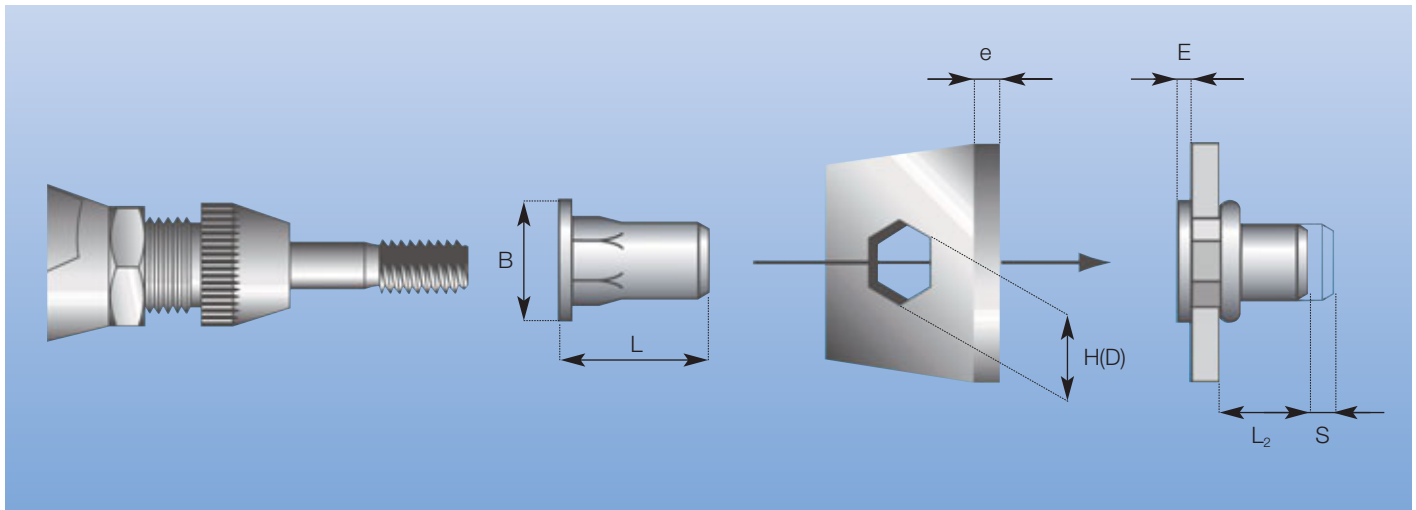

Type	Thread d	Material-thickness e	Hole-round (D) hexagonal (H)	Ø Head B	Projection after setting E	Setting stroke S	Total length L	Blind side projection after setting L ₂	Product code
------	----------	----------------------	------------------------------	----------	----------------------------	------------------	----------------	--	--------------

	M4	0.5 – 3.0	6	9	1.0	S = 4.5-e	11.3	5.8	2330 704 0230
	M5	0.5 – 3.0	7	10	1.0	S = 4.7-e	13.0	7.3	2330 705 0230
	M6	0.5 – 3.0	9	13	1.5	S = 5.0-e	14.5	8.0	2330 706 0230
	M6	3.0 – 5.5	9	13	1.5	S = 7.5-e	17.2	8.2	2330 706 0255
	M8	0.5 – 3.0	11	16	1.5	S = 5.5-e	18.0	11.0	2330 708 0230
	M8	3.0 – 5.5	11	16	1.5	S = 8.1-e	20.7	11.1	2330 708 0255
	M10	0.7 – 3.5	13	19	2.0	S = 6.1-e	22.0	13.9	2330 710 0235

	M4	0.5 – 3.0	6	9	1.0	S = 4.5-e	11.3	5.8	2334 104 0230
	M5	0.5 – 3.0	7	10	1.0	S = 4.7-e	13.0	7.3	2334 105 0230
	M6	0.5 – 3.0	9	13	1.5	S = 5.0-e	14.5	8.0	2334 106 0230
	M8	0.5 – 3.0	11	16	1.5	S = 5.3-e	18.0	11.2	2334 108 0230

Type	Thread d	Material - thickness e	Hole-round (D) hexagonal (H)	Ø Head B	Projection after setting E _{max}	Setting stroke S	Total length L	Blind side projection after setting L ₂	Product code
------	----------	------------------------	------------------------------	----------	---	------------------	----------------	--	--------------

	M4	0.5 – 3.0	6	6.7	0.3	S = 4.9-e	11.0	5.8	3436 704 0230
	M5	0.5 – 3.0	7	8.0	0.3	S = 5.3-e	13.0	7.4	3436 705 0230
	M6	0.5 – 3.0	9	10.0	0.4	S = 5.1-e	14.0	8.5	3436 706 0230
	M8	0.5 – 3.0	11	12.0	0.4	S = 6.0-e	17.5	11.1	3436 708 0230
	M10	0.7 – 3.5	13	14.0	0.5	S = 6.5-e	21.0	14.0	3436 710 0235

	M4	0.5 – 3.0	6	7.5	0.3	S = 4.7-e	11.0	6.0	3434 104 0230
	M5	0.5 – 3.0	7	8.7	0.3	S = 5.2-e	13.0	7.5	3434 105 0230
	M6	0.5 – 3.0	9	10.9	0.4	S = 5.3-e	14.0	8.3	3434 106 0230
	M8	0.5 – 3.0	11	13.3	0.4	S = 5.8-e	17.5	11.3	3434 108 0230

Dimensions in mm

Surface treatment: 8µ zinc plated + passivated (Cr (VI) free according ROHS directives and scrapped cars directives).

RIVKLE® steel

RIVKLE® stainless steel

RIVKLE® aluminium

RIVKLE® HRT

RIVKLE® PN
RIVKLE® Elastic

RIVKLE® blind rivet
studs, steel

Special designs

**RIVKLE® Steel blind rivet nuts/
Extending the RIVKLE®plus range**

Round body, plain, with flat head

Typen 2330 1 open and 2332 1 closed

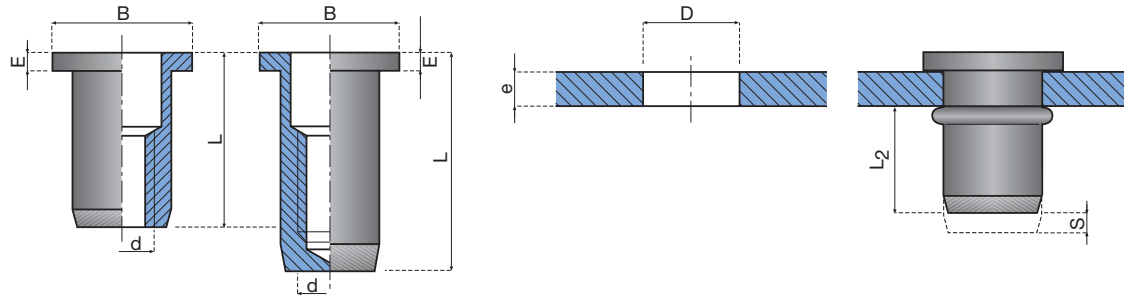

Advantages:

- High crimping force
- Screw length can be varied (open end)
- Splash-proof (closed end)

For the products shown in Blue we recommend the use of **RIVKLE®plus 2330 7**, page 15.

d	Thickness e	Hole D ^{+0.1/0}	B	E	S*	L	L ₂ *	Open Product code	L	L ₂ *	Closed Product code
M3	0.5 – 1.0	5	7.5	1.0	S = 2.8-e	8.5	4.8	2330 103 0010	12.5	8.8	2332 103 0010
	1.0 – 1.5	5	7.5	1.0	S = 3.3-e	9.0	4.8	2330 103 0015	13.0	8.8	2332 103 0015
	1.5 – 3.0	5	7.5	1.0	S = 4.8-e	10.0	4.8	2330 103 0030	14.0	8.8	2332 103 0030
	3.0 – 4.5	5	7.5	1.0	S = 6.3-e	11.5	4.8	2330 103 0045	15.5	8.8	2332 103 0045
	4.5 – 6.0	5	7.5	1.0	S = 7.8-e	13.0	4.8	2330 103 0060	17.0	8.8	2332 103 0060
M4	0.5 – 1.0	6	9.0	1.0	S = 2.6-e	10.0	5.4	2330 104 0010	15.0	10.4	2332 104 0010
	1.0 – 2.0	6	9.0	1.0	S = 3.6-e	10.5	5.4	2330 104 0020	15.5	10.4	2332 104 0020
	2.0 – 4.0	6	9.0	1.0	S = 5.6-e	12.0	5.4	2330 104 0040	17.0	10.4	2332 104 0040
	4.0 – 6.0	6	9.0	1.0	S = 7.6-e	14.0	5.4	2330 104 0060	19.0	10.4	2332 104 0060
M5	0.5 – 3.0	7	10.0	1.0	S = 5.0-e	14.0	8.0	2330 105 0030	20.0	14.0	2332 105 0030
	3.0 – 5.5	7	10.0	1.0	S = 7.5-e	17.0	8.0	2330 105 0055	23.0	14.0	2332 105 0055
	5.5 – 8.0	7	10.0	1.0	S = 10.0-e	20.0	8.0	2330 105 0080	26.0	14.0	2332 105 0080
M6	0.5 – 3.0	9	13.0	1.5	S = 5.2-e	16.0	10.0	2330 106 0030	23.0	17.0	2332 106 0030
	3.0 – 5.5	9	13.0	1.5	S = 7.7-e	19.0	10.0	2330 106 0055	26.0	17.0	2332 106 0055
	5.5 – 8.0	9	13.0	1.5	S = 10.2-e	22.0	10.0	2330 106 0080	29.0	17.0	2332 106 0080
M8	0.5 – 3.0	11	16.0	1.5	S = 5.7-e	18.0	11.0	2330 108 0030	26.0	19.0	2332 108 0030
	3.0 – 5.5	11	16.0	1.5	S = 8.2-e	21.0	11.0	2330 108 0055	29.0	19.0	2332 108 0055
	5.5 – 8.0	11	16.0	1.5	S = 10.7-e	24.0	11.0	2330 108 0080	32.0	19.0	2332 108 0080
	8.0 – 10.5	11	16.0	1.5	S = 13.2-e	27.0	11.0	2330 108 0105	35.0	19.0	2332 108 0105
M10	1.0 – 3.5	13	19.0	2.0	S = 6.5-e	23.0	15.0	2330 110 0035	33.0	25.0	2332 110 0035
	3.5 – 6.0	13	19.0	2.0	S = 9.0-e	26.0	15.0	2330 110 0060	36.0	25.0	2332 110 0060
	6.0 – 8.5	13	19.0	2.0	S = 11.5-e	29.0	15.0	2330 110 0085	39.0	25.0	2332 110 0085
	8.5 – 11.0	13	19.0	2.0	S = 14-e	32.0	15.0	2330 110 0110	42.0	25.0	2332 110 0110
	1.0 – 3.5	12	15.8	1.7	S = 7.0-e	19.0	11.0	2339 110 0703	/	/	/
M12	1.0 – 4.0	16	23.0	2.0	S = 7.7-e	27.0	17.5	2330 112 0040	39.0	29.5	2332 112 0040
	4.0 – 7.0	16	23.0	2.0	S = 10.7-e	30.0	17.5	2330 112 0070	42.0	29.5	2332 112 0070
	7.0 – 10.0	16	23.0	2.0	S = 13.7-e	33.0	17.5	2330 112 0100	45.0	29.5	2332 112 0100
M14**	1.5 – 3.0	18	24.0	2.5	S = 7.5-e	32.3	21.8	2330 114 0300	45.3	34.8	2332 114 0300
	3.0 – 4.5	18	24.0	2.5	S = 9.0-e	33.9	21.8	2330 114 0450	46.9	34.8	2332 114 0450
	4.5 – 6.0	18	24.0	2.5	S = 10.5-e	35.5	21.8	2330 114 0600	48.5	34.8	2332 114 0600
	6.0 – 7.5	18	24.0	2.5	S = 12.0-e	37.1	21.8	2330 114 0750	50.1	34.8	2332 114 0750
	7.5 – 9.0	18	24.0	2.5	S = 13.5-e	38.7	21.8	2330 114 0900	51.7	34.8	2332 114 0900

* Dimensions S and L₂ are indicative values. The difference in length S depends on the material thickness and is used as the setting tool stroke. Dimensions in mm. Surface treatment: 8µ zinc plated + passivated (Cr (VI) free according ROHS directives and scrapped cars directives). Other dimensions and variants can be supplied on request.

**Details of setting tools on request.

RIVKLE® Steel blind rivet nuts/
Extending the RIVKLE®plus range

Round body, plain, countersunk head

Types 2331 1 open and 2333 1 closed

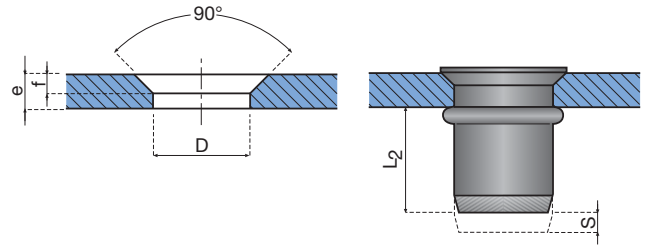
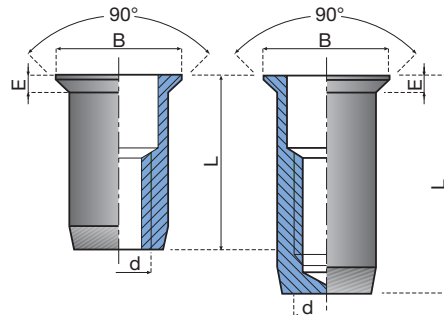

For the products shown in Blue we recommend the use of **RIVKLE®plus 3436 7**, page 15, which does not require any countersinking of the workpiece.

d	Thickness e	Hole D ^{+0.1/0}	f	B	E	S*	Open			Closed		
							L	L ₂ *	Product code	L	L ₂ *	Product code
M3	1.0 – 1.5	5	0.9	6.6	1.0	S = 2.8-e	8.5	4.8	2331 103 0015	12.5	8.8	2333 103 0015
	1.5 – 3.0	5	1.3	7.2	1.4	S = 4.3-e	9.0	4.8	2331 103 0030	13.0	8.8	2333 103 0030
	3.0 – 4.5	5	1.3	7.2	1.4	S = 5.8-e	10.5	4.8	2331 103 0045	14.5	8.8	2333 103 0045
	4.5 – 6.0	5	1.3	7.2	1.4	S = 6.3-e	12.0	4.8	2331 103 0060	16.0	8.8	2333 103 0060
M4	1.0 – 2.0	6	0.9	7.6	1.0	S = 3.7-e	10.0	5.4	2331 104 0020	15.0	10.4	2333 104 0020
	2.0 – 3.0	6	1.3	8.2	1.4	S = 4.7-e	10.5	5.4	2331 104 0030	15.5	10.4	2333 104 0030
	3.0 – 5.0	6	1.3	8.2	1.4	S = 6.7-e	12.0	5.4	2331 104 0050	17.0	10.4	2333 104 0050
	5.0 – 7.0	6	1.3	8.2	1.4	S = 8.7-e	14.0	5.4	2331 104 0070	19.0	10.4	2333 104 0070
M5	1.5 – 4.0	7	1.5	9.6	1.6	S = 6.5-e	14.0	8.0	2331 105 0040	20.0	14.0	2333 105 0040
	4.0 – 6.5	7	1.5	9.6	1.6	S = 9.0-e	17.0	8.0	2331 105 0065	23.0	14.0	2333 105 0065
	6.5 – 9.0	7	1.5	9.6	1.6	S = 11.5-e	20.0	8.0	2331 105 0090	26.0	14.0	2333 105 0090
M6	1.5 – 4.0	9	1.5	11.7	1.6	S = 6.2-e	16.0	10.0	2331 106 0040	23.0	17.0	2333 106 0040
	4.0 – 6.5	9	1.5	11.7	1.6	S = 8.7-e	19.0	10.0	2331 106 0065	26.0	17.0	2333 106 0065
	6.5 – 9.0	9	1.5	11.7	1.6	S = 11.2-e	22.0	10.0	2331 106 0090	29.0	17.0	2333 106 0090
M8	1.5 – 4.0	11	1.5	13.5	1.6	S = 7.0-e	18.0	11.0	2331 108 0040	26.0	19.0	2333 108 0040
	4.0 – 6.5	11	1.5	13.5	1.6	S = 9.5-e	21.0	11.0	2331 108 0065	29.0	19.0	2333 108 0065
	6.5 – 9.0	11	1.5	13.5	1.6	S = 12.0-e	24.0	11.0	2331 108 0090	32.0	19.0	2333 108 0090
M10	1.5 – 4.0	13	1.5	15.5	1.6	S = 7.3-e	22.0	15.0	2331 110 0040	32.0	25.0	2333 110 0040
	4.0 – 6.5	13	1.5	15.5	1.6	S = 9.8-e	25.0	15.0	2331 110 0065	35.0	25.0	2333 110 0065
	6.5 – 9.0	13	1.5	15.5	1.6	S = 12.3-e	28.0	15.0	2331 110 0090	38.0	25.0	2333 110 0090
M12	1.7 – 4.5	16	1.7	19.0	1.8	S = 8.2-e	26.0	17.5	2331 112 0045	38.0	29.5	2333 112 0045
	4.5 – 7.5	16	1.7	19.0	1.8	S = 11.2-e	29.0	17.5	2331 112 0075	41.0	29.5	2333 112 0075
	7.5 – 10.5	16	1.7	19.0	1.8	S = 14.2-e	32.0	17.5	2331 112 0105	44.0	29.5	2333 112 0105
M14**	3.0 – 4.5	18	3.0	23.7	3.1	S = 9.0-e	31.4	21.8	2331 114 0450	44.4	34.8	2333 114 0450
	4.5 – 6.0	18	3.5	24.0	3.6	S = 10.5-e	33.0	21.8	2331 114 0600	46.0	34.8	2333 114 0600
	6.0 – 7.5	18	3.5	24.0	3.6	S = 12.0-e	34.6	21.8	2331 114 0750	47.6	34.8	2333 114 0750
	7.5 – 9.0	18	3.5	24.0	3.6	S = 13.5-e	36.2	21.8	2331 114 0900	49.2	34.8	2333 114 0900

* Dimensions S and L₂ are indicative values. The difference in length S depends on the material thickness and is used as the setting tool stroke. Note: Countersink angle 90°. The optimum countersink depth f is slightly less than E. Dimensions in mm.

Surface treatment: 8µ zinc plated + passivated (Cr (VI) free according ROHS directives and scrapped cars directives). Other dimensions and variants can be supplied on request.

**Details of setting tools on request.

RIVKLE® steel

RIVKLE® stainless steel

RIVKLE® aluminium

RIVKLE® HRT

RIVKLE® PN
RIVKLE® Elastic

RIVKLE® blind rivet
studs, steel

Special designs

RIVKLE® Steel blind rivet nuts/
Extending the RIVKLE®plus range

Round body, linear knurls in grip range, flat head

Types 2330 7 open and 2332 7 closed

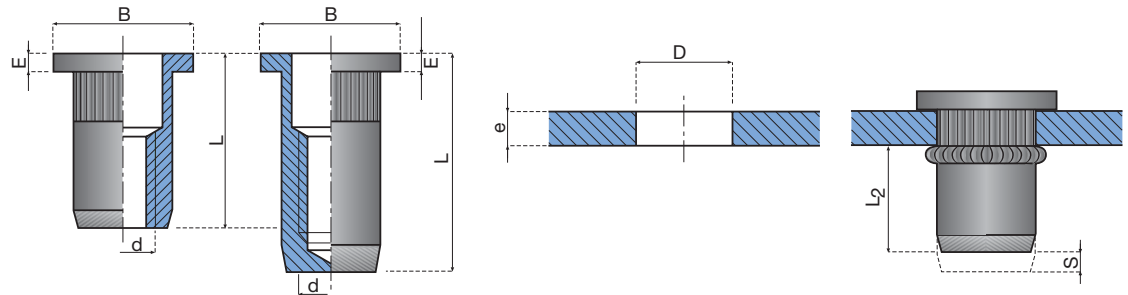
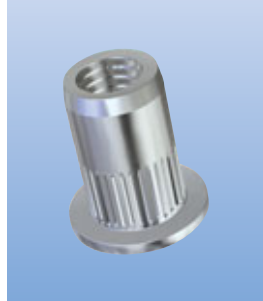

Advantages:

- Increased turning resistance
- Suitable for soft components (aluminium, plastic,...)
- High crimping force
- Screw length can be varied (open end)
- Splash-proof (closed end)

For the products shown in Blue we recommend the use of **RIVKLE®plus 2330 7**, page 15.

d	Thickness e	Hole D ^{+0.1/0}	B	E	S*	Open			Closed		
						L	L ₂ *	Product code	L	L ₂ *	Product code
M3	0.75 – 1.00	5	7	1.0	S = 2.2-e	8.8	6.0	2330 703 0100	13.1	10.3	2332 703 0100
	1.00 – 1.75	5	7	1.0	S = 3.0-e	9.6	6.0	2330 703 0175	13.9	10.3	2332 703 0175
	1.75 – 2.50	5	7	1.0	S = 3.7-e	10.4	6.0	2330 703 0250	14.7	10.3	2332 703 0250
	2.50 – 3.25	5	7	1.0	S = 4.6-e	11.2	6.0	2330 703 0325	15.5	10.3	2332 703 0325
M4	0.75 – 1.00	6	8	1.0	S = 2.2-e	9.2	6.3	2330 704 0100	14.2	11.3	2332 704 0100
	1.00 – 1.75	6	8	1.0	S = 3.0-e	10.0	6.3	2330 704 0175	15.0	11.3	2332 704 0175
	1.75 – 2.50	6	8	1.0	S = 3.7-e	10.8	6.3	2330 704 0250	15.8	11.3	2332 704 0250
	2.50 – 3.25	6	8	1.0	S = 4.6-e	11.6	6.3	2330 704 0325	16.6	11.3	2332 704 0325
M5	0.50 – 1.00	7	10**	1.0	S = 3.0-e	12.0	8.0	2330 705 0010	17.6	14.6	2332 705 0100
	1.00 – 2.00	7	10**	1.0	S = 4.0-e	13.0	8.0	2330 705 0020	18.7	14.6	2332 705 0200
	2.00 – 3.00	7	10**	1.0	S = 5.0-e	14.0	8.0	2330 705 0030	19.8	14.6	2332 705 0300
	3.00 – 4.00	7	10**	1.0	S = 6.0-e	15.0	8.0	2330 705 0040	20.9	14.6	2332 705 0400
M6	0.70 – 1.50	9	13**	1.5	S = 3.5-e	14.5	10.0	2330 706 0015	22.0	17.0	2332 706 0150
	1.50 – 3.00	9	13**	1.5	S = 5.0-e	16.0	10.0	2330 706 0030	23.6	17.0	2332 706 0300
	3.00 – 4.50	9	13**	1.5	S = 6.5-e	17.5	10.0	2330 706 0045	25.2	17.0	2332 706 0450
M8	1.00 – 2.00	11	16**	1.5	S = 5.0-e	17.0	10.8	2330 708 0020	25.0	18.8	2332 708 0200
	2.00 – 3.50	11	16**	1.5	S = 6.5-e	18.5	10.8	2330 708 0035	26.5	18.8	2332 708 0350
	3.50 – 5.00	11	16**	1.5	S = 8.0-e	20.0	10.8	2330 708 0050	28.0	18.8	2332 708 0500
M10	1.00 – 1.50	13	16	2.0	S = 4.5-e	20.8	15.0	2330 710 0150	30.7	24.9	2332 710 0150
	1.50 – 3.00	13	16	2.0	S = 6.0-e	22.4	15.0	2330 710 0300	32.3	24.9	2332 710 0300
	3.00 – 4.50	13	16	2.0	S = 7.5-e	24.0	15.0	2330 710 0450	33.9	24.9	2332 710 0450
	4.50 – 6.00	13	16	2.0	S = 9.0-e	25.6	15.0	2330 710 0600	35.5	24.9	2332 710 0600

* Dimensions S and L₂ are indicative values. The difference in length S depends on the material thickness and is used as the setting tool stroke.

** 9 mm in 23327 M5 (closed), 11 mm in 23327 M6 (closed), 14 mm in 23327 M8 (closed).

Dimensions in mm.

Surface treatment: 8 μ zinc plated + passivated (Cr (VI) free according ROHS directives and scrapped cars directives).

Other dimensions and variants can be supplied on request.

RIVKLE® Steel blind rivet nuts/
Extending the RIVKLE®plus range

Round body, linear knurls in grip range,
countersunk head

Types 2331 7 open and 2333 7 closed

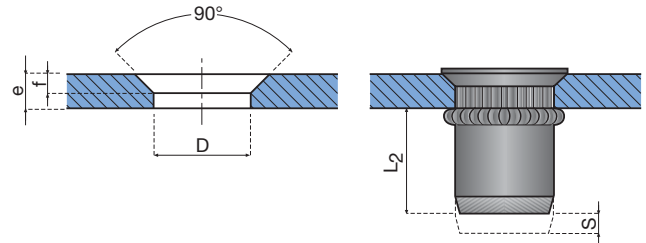
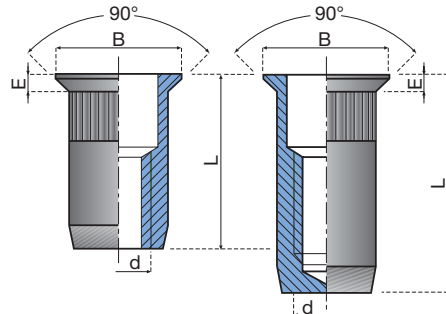

Advantages:

- Increased turning resistance
- Suitable for soft components (aluminium, plastic,...)
- Very small head projection
- High crimping force
- Screw length can be varied (open end)
- Splash-proof (closed end)

For the products shown in Blue we recommend the use of **RIVKLE®plus 3436 7**, page 15, which does not require any countersinking of the workpiece.

d	Thickness e	Hole D ^{+0.1/0}	f	B	E	S*	Open			Closed		
							L	L ₂ *	Product code	L	L ₂ *	Product code
M3	1.00 – 1.75	5	1.0	7	1.1	S = 3.2-e	8.8	6.0	2331 703 0175	13.1	10.3	2333 703 0175
	1.75 – 2.50	5	1.2	7	1.3	S = 4.0-e	9.6	6.0	2331 703 0250	13.9	10.3	2333 703 0250
	2.50 – 3.25	5	1.2	7	1.3	S = 4.7-e	10.4	6.0	2331 703 0325	14.7	10.3	2333 703 0325
M4	1.00 – 1.75	6	1.0	8	1.1	S = 3.2-e	9.2	6.3	2331 704 0175	14.2	11.3	2333 704 0175
	1.75 – 2.50	6	1.2	8	1.3	S = 4.0-e	10.0	6.3	2331 704 0250	15.0	11.3	2333 704 0250
	2.50 – 3.25	6	1.2	8	1.3	S = 4.7-e	10.8	6.3	2331 704 0325	15.8	11.3	2333 704 0325
M5	1.00 – 2.00	7	1.0	9	1.1	S = 4.0-e	11.6	8.5	2331 705 0200	17.7	14.6	2333 705 0200
	2.00 – 3.00	7	1.4	9	1.5	S = 5.0-e	12.7	8.5	2331 705 0300	18.8	14.6	2333 705 0300
	3.00 – 4.00	7	1.4	9	1.5	S = 6.0-e	13.8	8.5	2331 705 0400	19.9	14.6	2333 705 0400
	4.00 – 5.00	7	1.4	9	1.5	S = 7.0-e	14.9	8.5	2331 705 0500	21.0	14.6	2333 705 0500
M6	1.50 – 3.00	9	1.2	11	1.3	S = 5.0-e	15.0	10.0	2331 706 0300	22.0	17.0	2333 706 0300
	3.00 – 4.50	9	1.5	11	1.6	S = 6.5-e	16.6	10.0	2331 706 0450	23.6	17.0	2333 706 0450
	4.50 – 6.00	9	1.5	11	1.6	S = 8.0-e	18.2	10.0	2331 706 0600	25.2	17.0	2333 706 0600
	6.00 – 7.50	9	1.5	11	1.6	S = 9.5-e	19.8	10.0	2331 706 0750	26.8	17.0	2333 706 0750
M8	1.50 – 3.00	11	1.4	13	1.5	S = 6.0-e	16.5	11.5	2331 708 0300	24.8	19.8	2333 708 0300
	3.00 – 4.50	11	2.0	14	2.1	S = 7.5-e	18.1	11.5	2331 708 0450	26.4	19.8	2333 708 0450
	4.50 – 6.00	11	2.0	14	2.1	S = 9.0-e	19.7	11.5	2331 708 0600	28.0	19.8	2333 708 0600
	6.00 – 7.50	11	2.0	14	2.1	S = 10.5-e	21.3	11.5	2331 708 0750	29.6	19.8	2333 708 0750
M10	1.50 – 3.00	13	1.4	15	1.5	S = 6.0-e	20.4	15.0	2331 710 0300	30.3	24.9	2333 710 0300
	3.00 – 4.50	13	2.0	16	2.1	S = 7.5-e	22.0	15.0	2331 710 0450	31.9	24.9	2333 710 0450
	4.50 – 6.00	13	2.0	16	2.1	S = 9.0-e	23.6	15.0	2331 710 0600	33.5	24.9	2333 710 0600

* Dimensions S and L₂ are indicative values. The difference in length S depends on the material thickness and is used as the setting tool stroke.
 Note: Countersink angle 90°. the optimum countersink depth f is slightly less than E.
 Dimensions in mm.

Surface treatment: 8µ zinc plated + passivated (Cr (VI) free according ROHS directives and scrapped cars directives).
 Other dimensions and variants can be supplied on request.

RIVKLE® steel

RIVKLE® stainless steel

RIVKLE® aluminium

RIVKLE® HRT

RIVKLE® PN
 RIVKLE® Elastic

RIVKLE® blind rivet
 studs, steel

Special designs

**RIVKLE® Steel blind rivet nuts/
Extending the RIVKLE®plus range**

Hexagonal body, flat head

Types 2334 1 open and 2335 1 closed

Advantages:

- Very high turning resistance
- Suitable for soft components (aluminium, plastic,...)
- High crimping force
- Screw length can be varied (open end)
- Splash-proof (closed end)

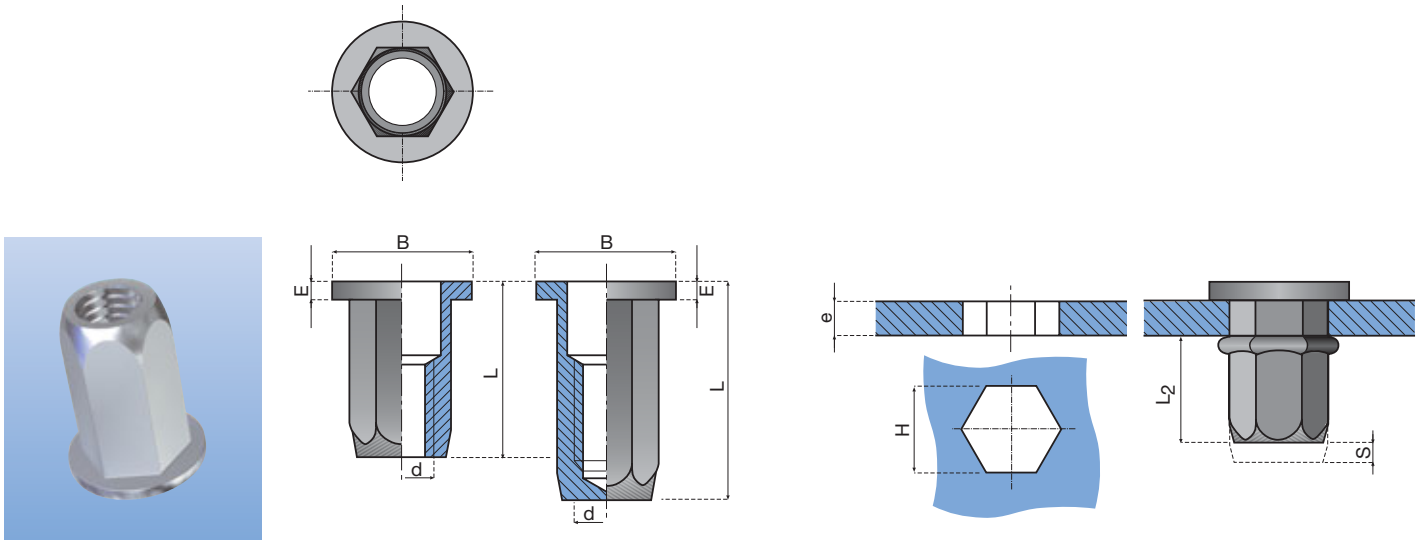

d	Thickness e	Hole H ^{+0.1/0}	B	E	S*	Open			Closed		
						L	L ₂ *	Product code	L	L ₂ *	Product code
M4	0.5 – 2.0	6	9	1.0	S = 3.5-e	10.0	5	2334 104 0020	15	10.0	2335 104 0020*
M5	0.5 – 3.0	7	10	1.0	S = 5.0-e	14.0	9	2334 105 0030	20	14.7	2335 105 0030
M6	0.5 – 3.0	9	13	1.5	S = 5.2-e	16.0	10	2334 106 0030	23	17.0	2335 106 0030
M6	3.0 – 5.5	9	13	1.5	S = 7.5-e	19.0	10	2334 106 0055	/	/	/
M8	0.5 – 3.0	11	16	1.5	S = 5.5-e	18.0	11	2334 108 0030	26	19.0	2335 108 0030
M8	3.0 – 5.5	11	16	1.5	S = 8.0-e	21.0	11	2334 108 0055	29	19.0	2335 108 0055
M10	1.0 – 3.5	13	19	2.0	S = 6.1-e	23.0	15	2334 110 0035	33	25.0	2335 110 0035
M10	3.5 – 6.0	13	19	2.0	S = 8.7-e	25.7	15	2334 110 0060	/	/	/
M12	1.0 – 4.0	16	23	2.0	S = 7.7-e	27.0	17	2334 112 0030	/	/	/

* Dimensions S and L₂ are indicative values. The difference in length S depends on the material thickness and is used as the setting tool stroke. Dimensions in mm.

Surface treatment: 8µ zinc plated + passivated (Cr (VI) free according ROHS directives and scrapped cars directives).

Other dimensions and variants can be supplied on request.

**RIVKLE® Steel blind rivet nuts/
Extending the RIVKLE®plus range**

Round body, plain, extra-small countersunk head

Type 3430 1 for holes with imperial dimensions

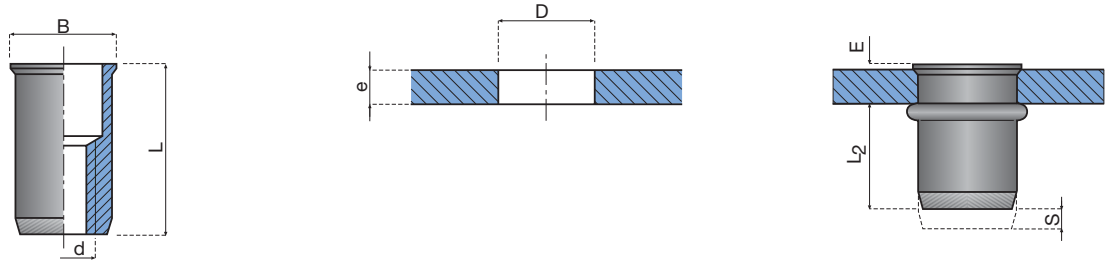

For the products shown in Blue we recommend the use of **RIVKLE®plus 3436 7**, page 15, where there are holes with metric dimensions.

d	Thickness e	Hole D ^{+0.1/0}	B	E _{max.}	S*	L	L ₂ *	Product code
M3	0.5 – 1.5	4.7	5.2	0.4	S = 3.0-e	8.4	5.5	3430 103 0150
M4	0.5 – 2.0	6.4	6.7	0.5	S = 3.5-e	10.4	7.3	3430 104 0150
M5	0.5 – 3.0	7.1	7.5	0.6	S = 4.5-e	11.5	7.3	3430 105 0150
M6	0.7 – 3.0	9.5	10.2	0.6	S = 5.5-e	14.5	9.3	3430 106 0200
M8	0.8 – 4.5	10.5	11.3	0.7	S = 7.5-e	16.8	9.6	3430 108 0450

* Dimensions S and L₂ are indicative values. the difference in length S depends on the material thickness and is used as the setting tool stroke.

Dimensions in mm.

Surface treatment: 8µ zinc plated + passivated (Cr (VI) free according ROHS directives and scrapped cars directives).

D = the imperial dimensions are expressed in mm.

Other dimensions and variants can be supplied on request.

Advantages:

- Very small head projection without countersinking
- Screw length can be varied

RIVKLE® steel

RIVKLE® stainless steel

RIVKLE® aluminium

RIVKLE® HRT

RIVKLE® PN
RIVKLE® Elastic

RIVKLE® blind rivet
studs, steel

Special designs

RIVKLE® Steel blind rivet nuts/
Extending the RIVKLE®plus range

Round body, linear knurls in grip range,
with extra-small countersunk head

Types 3436 7 open and 3437 7 closed

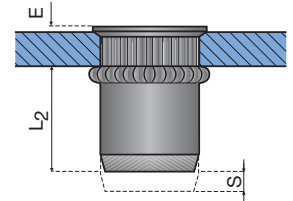
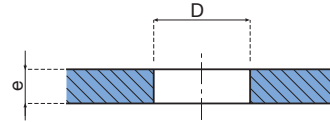
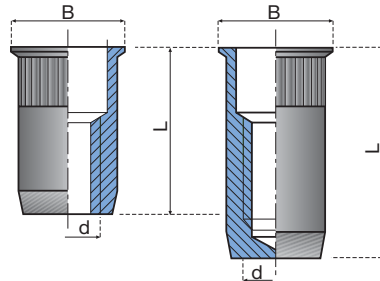

Advantages:

- Very small head projection without countersinking
- Increased turning resistance
- Suitable for soft components (aluminium, plastic,...)
- Screw length can be varied (open end)
- Splash-proof (closed end)

For the products shown in Blue we recommend the use of **RIVKLE®plus 3436 7**, page 15.

d	Thickness e	Hole D ^{+0,1/0}	B	E _{max}	S*	Open			Closed		
						L	L ₂ *	Product code	L	L ₂ *	Product code
M3	0.7 – 1.5	5	6	0.4	S = 2.0-e	8.3	5.8	3436 703 0015	12.6	10.1	3437 703 0015
	1.5 – 3.0	5	6	0.4	S = 3.6-e	9.8	5.7	3436 703 0030	14.1	10.0	3437 703 0030
M4	0.7 – 2.5	6	7	0.4	S = 4.0-e	see page 15			15.3	10.9	3437 704 0025
	2.5 – 4.0	6	7	0.4	S = 5.6-e	11.9	5.9	3436 704 0040	16.9	10.9	3437 704 0040
M5	0.7 – 2.5	7	8	0.4	S = 4.2-e	see page 15			18.2	13.6	3437 705 0025
	2.5 – 4.0	7	8	0.4	S = 5.8-e	13.8	7.6	3436 705 0040	19.8	13.6	3437 705 0040
M6	0.8 – 3.0	9	10	0.4	S = 4.7-e	see page 15			18.7	5.0	3437 706 0030
	3.0 – 4.5	9	10	0.4	S = 6.3-e	15.3	8.6	3436 706 0045	20.3	13.6	3437 706 0045
	4.5 – 6.0	9	10	0.4	S = 7.9-e	16.9	8.6	3436 706 0060	21.9	13.6	3437 706 0060
M8	0.8 – 3.0	11	12	0.5	S = 4.8-e	see page 15			23.3	6.0	3437 708 0030
	3.0 – 4.5	11	12	0.5	S = 6.4-e	18.9	12	3436 708 0045	24.9	18.0	3437 708 0045
	4.5 – 6.0	11	12	0.5	S = 8.0-e	20.5	12	3436 708 0060	26.5	18.0	3437 708 0060
M10	0.8 – 3.0	13	14	0.5	S = 5.5-e	see page 15			28.3	22.3	3437 710 0030
	3.0 – 4.5	13	14	0.5	S = 7.1-e	21.9	14.3	3436 710 0045	29.9	22.3	3437 710 0045
	4.5 – 6.0	13	14	0.5	S = 8.7-e	23.5	14.3	3436 710 0060	31.5	22.3	3437 710 0060
M12	0.8 – 3.0	16	17	0.5	S = 5.9-e	24.2	17.8	3436 712 0030	33.2	26.8	3437 712 0030
	3.0 – 4.5	16	17	0.5	S = 7.5-e	25.8	17.8	3436 712 0045	34.8	26.8	3437 712 0045
	4.5 – 6.0	16	17	0.5	S = 9.1-e	27.4	17.8	3436 712 0060	36.4	26.8	3437 712 0060

* Dimensions S and L₂ are indicative values. The difference in length S depends on the material thickness and is used as the setting tool stroke. Dimensions in mm.

Surface treatment: 8µ zinc plated + passivated (Cr (VI) free according ROHS directives and scrapped cars directives).

Other dimensions and variants can be supplied on request.

RIVKLE® Steel blind rivet nuts/
Extending the RIVKLE®plus range

Hexagonal body, extra-small countersunk head

Types 3434 1 open and 3435 1 closed for holes with metric dimensions

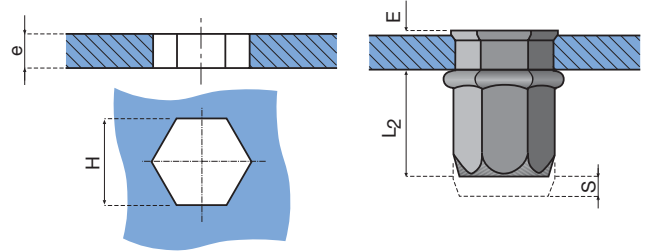
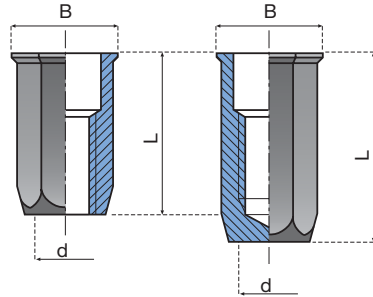

For the products shown in Blue we recommend the use of **RIVKLE®plus 3434 1**, page 15.

d	Thickness e	Hole H ^{+0.1/0}	B	E _{max.}	S*	Open			Closed		
						L	L ₂ *	Product code	L	L ₂ *	Product code
M4	0.5 – 2.0	6	7.5	0.5	S = 3.5-e	10	6.2	3434 104 0020	17	13.2	3435 104 0020
M5	0.5 – 3.0	7	9.0	0.6	S = 4.5-e	14	9.0	3434 105 0030	20	15.0	3435 105 0030
M6	0.5 – 3.0	9	11.1	0.6	S = 5.5-e	16	10.2	3434 106 0030	23	17.2	3435 106 0030
M6	4.0 – 6.0	9	11.1	0.6	S = 8.5-e	19	10.2	3434 106 0060	/	/	/
M8	0.7 – 3.0	11	13.4	0.7	S = 5.2-e	18	12.5	3434 108 0030	28	22.5	3435 108 0030
M8	4.0 – 6.0	11	13.4	0.7	S = 8.2-e	21	16.0	3434 108 0060	/	/	/
M10	1.0 – 3.5	13	16.0	0.8	S = 6.0-e	22	16.0	3434 110 0035	/	/	/
M10	3.0 – 6.0	13	16.0	0.8	S = 8.6-e	25	16.0	3434 110 0060	/	/	/
M12	1.0 – 4.0	16	18.8	1.0	S = 7.5-e	25	16.0	3434 112 0040	/	/	/
M12	4.0 – 8.0	16	18.8	1.0	S = 12.5-e	27.7	16.0	3434 112 0080	/	/	/

* Dimensions S and L₂ are indicative values. The difference in length S depends on the material thickness and is used as the setting tool stroke. Dimensions in mm. Surface treatment: 8 μ zinc plated + passivated (Cr (VI) free according ROHS directives and scrapped cars directives). Other dimensions and variants can be supplied on request.

Type 3432 1 for holes with imperial dimensions

Where possible we recommend the use of **RIVKLE®plus** for holes with metric dimensions.

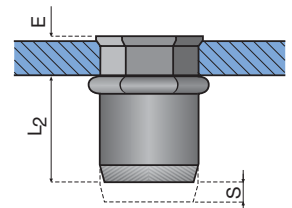
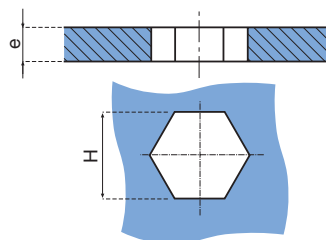
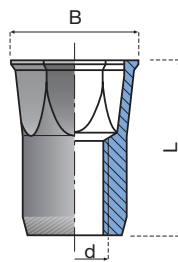

For the products shown in Blue we recommend the use of **RIVKLE®plus 3434 1**, page 15.

d	Thickness e	Hole H ^{+0.1/0}	B	E _{max.}	S*	L	L ₂ *	Product code
M4	0.5 – 2.0	6.4	7.65	0.5	S = 4.0-e	10.4	6.8	3432 104 0020
M5	0.5 – 3.0	7.3	8.75	0.6	S = 5.0-e	11.8	7.0	3432 105 0030
M6	0.7 – 3.0	9.7	11.45	0.6	S = 5.2-e	14.6	9.5	3432 106 0030
M8	0.9 – 3.3	10.7	12.70	0.7	S = 5.9-e	16.0	10.2	3432 108 0033

* Dimensions S and L₂ are indicative values. The difference in length S depends on the material thickness and is used as the setting tool stroke. Dimensions in mm. H = The imperial dimensions are expressed in mm. Surface treatment: 8 μ zinc plated + passivated (Cr (VI) free according ROHS directives and scrapped cars directives). Other dimensions and variants can be supplied on request.

Advantages:

- Very high turning resistance
- Suitable for soft components (aluminium, plastic,...)
- Very small head projection without countersinking
- Screw length can be varied (open end)
- Splash-proof (closed end)

RIVKLE® steel

RIVKLE® stainless steel

RIVKLE® aluminium

RIVKLE® HRT

RIVKLE® PN
RIVKLE® Elastic

RIVKLE® blind rivet
studs, steel

Special designs

**RIVKLE® Steel blind rivet nuts/
Extending the RIVKLE®plus range**

**Hexagonal body, extra-small countersunk head
and optimised head projection**

Types 3439 1 for holes with metric dimensions

Advantages:

- Very high turning resistance
- Suitable for soft components (aluminium, plastic,...)
- Very small head projection without countersinking
- Screw length can be varied

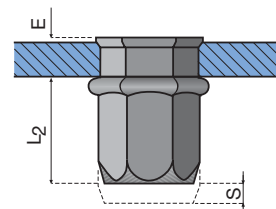
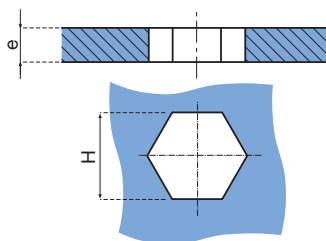
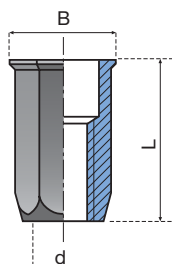

For the products shown in Blue we recommend the use of **RIVKLE®plus 3434 1**, page 15.

d	Thickness e	Hole H ^{+0.1/0}	B	E _{max.}	S*	L	L ₂ *	Product code
M4	0.5 – 2.0	6	7.5	0.3	S = 3.5-e	9.5	6.2	3439 104 0679
M5	0.5 – 3.0	7	9.0	0.3	S = 4.5-e	13.5	9.0	3439 105 0612
M6	0.5 – 3.0	9	11.1	0.3	S = 5.5-e	15.5	10.2	3439 106 0613
M6	4.0 – 6.0	9	11.1	0.3	S = 8.5-e	18.5	10.2	3439 106 0680
M8	0.7 – 3.0	11	13.4	0.4	S = 5.2-e	17.5	12.5	3439 108 0614
M8	4.0 – 6.0	11	13.4	0.4	S = 8.2-e	20.5	12.5	3439 108 0620
M10	1.0 – 3.5	13	16.0	0.4	S = 6.0-e	21.5	16.0	3439 110 0618
M10	3.0 – 6.0	13	16.0	0.4	S = 8.6-e	24.5	16.0	3439 110 0619
M12	1.0 – 4.0	16	18.8	0.5	S = 7.5-e	24.5	16.0	3439 112 0616
M12	4.0 – 8.0	16	18.8	0.5	S = 12.5-e	27.2	16.0	3439 112 0615

* Dimensions S and L₂ are indicative values. The difference in length S depends on the material thickness and is used as the setting tool stroke. Dimensions in mm.

Surface treatment: 8µ zinc plated + passivated (Cr (VI) free according ROHS directives and scrapped cars directives). Other dimensions and variants can be supplied on request.

Extra small countersunk heads were developed for applications in which the gap between the parts to be fitted must be reduced to zero for technical design or aesthetic reasons. It is not necessary to countersink the holes in this case.

However, they cannot be used as an alternative to countersunk heads:

- If the hole is not exactly within the tolerance margins
- If the hole material is ductile (to prevent the head from pulling through)
- If a screw has a tilting effect on the blind rivet nut.

(See also page 9).

RIVKLE® Stainless steel blind rivet nuts

Round body, plain, flat head

Type 2330 8

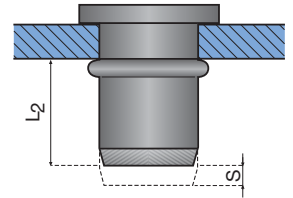
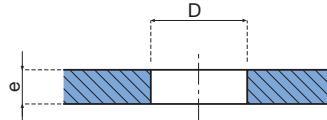
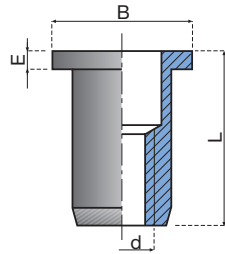

Advantages:

- High crimping force
- High corrosion resistance
- Screw length can be varied
- Suitable for use in the food processing industry

d	Thickness e	Hole D ^{+0.1/0}	B	E	S*	L	L ₂ *	Product code
M4	0.80 – 1.75	6	8	1.0	S = 3.6-e	11.4	6.8	2330 804 0175
	1.75 – 2.50	6	8	1.0	S = 4.4-e	12.2	6.8	2330 804 0250
	2.50 – 3.25	6	8	1.0	S = 6.0-e	13.6	6.8	2330 804 0325
M5	0.80 – 2.00	7	9	1.0	S = 3.0-e	12.6	8.0	2330 805 0200
	2.00 – 3.00	7	9	1.0	S = 5.1-e	13.5	8.0	2330 805 0300
	3.00 – 4.00	7	9	1.0	S = 5.0-e	14.5	8.0	2330 805 0400
M6	0.80 – 3.00	9	12	1.5	S = 4.7-e	15.8	9.5	2330 806 0300
	3.00 – 4.50	9	12	1.5	S = 6.3-e	17.5	9.5	2330 806 0450
M8	0.80 – 3.00	11	14	1.5	S = 4.7-e	16.3	10.0	2330 808 0300
	3.00 – 4.50	11	14	1.5	S = 6.1-e	17.7	10.0	2330 808 0450
M10	1.00 – 3.00	13	16	2.0	S = 4.6-e	22.4	16.0	2330 810 0300
	3.00 – 4.50	13	16	2.0	S = 6.7-e	24.0	16.0	2330 810 0450
	4.50 – 6.00	13	16	2.0	S = 7.8-e	25.6	16.0	2330 810 0600

* Dimensions S and L₂ are indicative values. The difference in length S depends on the material thickness and is used the setting tool stroke.

Dimensions in mm.

Other dimensions and variants can be supplied on request.

RIVKLE® steel

RIVKLE® stainless steel

RIVKLE® aluminium

RIVKLE® HRT

RIVKLE® PN
RIVKLE® Elastic

RIVKLE® blind rivet
studs, steel

Special designs

RIVKLE® Stainless steel blind rivet nuts

Round body, plain, countersunk head

Typ 2331 8

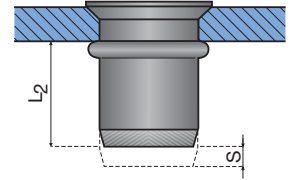
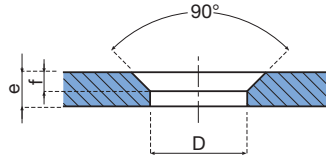
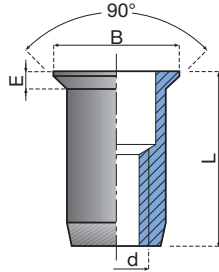

Advantages:

- Very small head projection
- High crimping force
- High corrosion resistance
- Screw length can be varied
- Suitable for use in the food processing industry

d	Thickness e	Hole D ^{+0.1/0}	f	B	E	S*	L	L ₂ *	Product code
M4	1.30 – 2.50	6	1.3	8	1.4	S = 4.4-e	11.3	6.8	2331 804 0250
	2.50 – 3.25	6	1.3	8	1.4	S = 6.0-e	10.8	6.8	2331 804 0325
M5	1.50 – 3.00	7	1.5	9.6	1.6	S = 4.0-e	12.5	8.5	2331 805 0300
	3.00 – 4.00	7	1.5	9.6	1.6	S = 6.8-e	13.8	8.5	2331 805 0400
M6	1.50 – 3.00	9	1.5	11.5	1.6	S = 4.9-e	14.8	9.5	2331 806 0300
	3.00 – 4.50	9	1.5	11.7	1.6	S = 5.4-e	16.6	9.5	2331 806 0450
	4.50 – 6.00	9	1.5	11.7	1.6	S = 7.0-e	18.2	9.5	2331 806 0600
M8	1.50 – 3.00	11	1.5	13.5	1.6	S = 5.0-e	16.3	10.5	2331 808 0300
	3.00 – 4.50	11	1.5	13.5	1.6	S = 5.9-e	18.1	12.2	2331 808 0450
	4.50 – 6.00	11	1.5	13.5	1.6	S = 7.5-e	19.7	12.2	2331 808 0600
M10	1.50 – 3.00	13	1.5	15.5	1.6	S = 4.2-e	20.4	16.2	2331 810 0300
	3.00 – 4.50	13	1.5	15.5	1.6	S = 6.7-e	22.0	16.2	2331 810 0450
	4.50 – 6.00	13	1.5	15.5	1.6	S = 7.4-e	23.6	16.2	2331 810 0600

* Dimensions S and L₂ are indicative values. The difference in length S depends on the material thickness and is used as the setting tool stroke.

Note: Countersink angle 90°. The optimum countersink depth f is slightly less than E.

Dimensions in mm.

Other dimensions and variants can be supplied on request.

RIVKLE® Stainless steel blind rivet nuts

Round body, linear knurls in grip range, flat head

Types 2330 6 open and 2332 6 closed

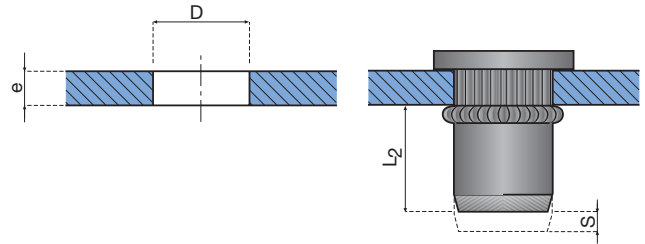
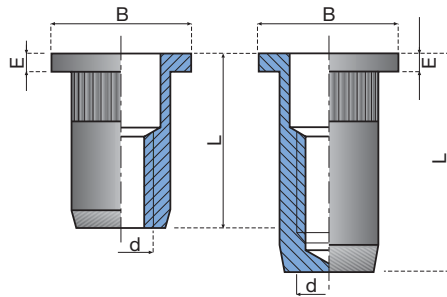

Advantages:

- Increased turning resistance
- Suitable for soft components (aluminium, plastic,...)
- High crimping force
- High corrosion resistance
- Screw length can be varied (open end)
- Splash-proof (closed end)
- Suitable for use in the food processing industry

d	Thickness e	Hole D ^{+0.1/0}	B	E	S*	Open			Closed		
						L	L ₂ *	Product code	L	L ₂ *	Product code
M3	0.7 - 1.5	5.0	7.0	1.0	S = 2.4-e	9.3	5.9	2330 603 0015	13.6	10.2	2332 603 0015
	1.5 - 2.5	5.0	7.0	1.0	S = 3.5-e	10.4	5.9	2330 603 0025	14.7	10.2	2332 603 0025
M4	0.7 - 3.3	6.0	8.0	1.0	S = 4.0-e	12.0	7.0	2330 604 0233	/	/	/
	0.7 - 1.5	6.0	8.0	1.0	S = 2.6-e	/	/	/	14.8	11.2	2332 604 0015
	1.5 - 2.5	6.0	8.0	1.0	S = 3.6-e	/	/	/	15.6	11.0	2332 604 0025
	2.5 - 3.5	5.0	8.0	1.0	S = 4.7-e	11.7	6.0	2330 604 0035	16.7	11.0	2332 604 0035
M5	0.7 - 3.3	7.0	9.0	1.0	S = 5.3-e	12.7	7.2	2330 605 0233	/	/	/
	0.7 - 1.5	7.0	9.0	1.0	S = 2.8-e	/	/	/	17.8	14.0	2332 605 0015
	1.5 - 3.0	7.0	9.0	1.0	S = 4.5-e	/	/	/	19.3	13.8	2332 605 0030
	3.0 - 4.0	7.0	9.0	1.0	S = 5.6-e	14.4	7.8	2330 605 0040	20.4	13.8	2332 605 0040
M6	0.7 - 3.3	9.0	12.0	1.5	S = 5.7-e	15.2	8.6	2330 606 0233	/	/	/
	3.0 - 5.5	9.0	12.0	1.5	S = 7.5-e	17.5	8.6	2330 606 0255	/	/	/
	0.8 - 1.5	9.0	11.0	1.5	S = 3.1-e	/	/	/	18.3	13.7	2332 606 0015
	1.5 - 3.0	9.0	11.0	1.5	S = 4.7-e	/	/	/	19.8	13.6	2332 606 0030
	3.0 - 4.5	9.0	11.0	1.5	S = 6.3-e	/	/	/	21.4	13.6	2332 606 0045
	4.5 - 6.0	9.0	11.0	1.5	S = 7.9-e	18.2	8.6	2330 606 0060	23.2	13.6	2332 606 0060
M8	0.7 - 3.3	11.0	14.0	1.5	S = 6.5-e	16.9	9.5	2330 608 0233	/	/	/
	3.0 - 5.5	11.0	14.0	1.5	S = 8.5-e	19.0	9.5	2330 608 0255	/	/	/
	0.8 - 1.5	11.0	14.0	1.5	S = 3.2-e	/	/	/	21.3	16.6	2332 608 0015
	1.5 - 3.0	11.0	14.0	1.5	S = 4.7-e	/	/	/	22.8	16.6	2332 608 0030
	3.0 - 4.5	11.0	14.0	1.5	S = 6.3-e	/	/	/	24.4	16.6	2332 608 0045
M10	4.5 - 6.0	11.0	14.0	1.5	S = 7.9-e	20.0	10.6	2330 608 0060	26.0	16.6	2332 608 0060
	0.8 - 1.5	13.0	16.0	2.0	S = 3.9-e	19.8	13.9	2330 610 0015	27.8	21.9	2332 610 0015
	1.5 - 3.0	13.0	16.0	2.0	S = 5.5-e	21.4	13.9	2330 610 0030	29.4	21.9	2332 610 0030
	3.0 - 4.5	13.0	16.0	2.0	S = 7.1-e	23.0	13.9	2330 610 0045	31.0	21.9	2332 610 0045
M12	4.5 - 6.0	13.0	16.0	2.0	S = 8.7-e	24.6	13.9	2330 610 0060	32.6	21.9	2332 610 0060
	0.8 - 1.5	16.0	20.0	2.0	S = 3.8-e	23.0	17.2	2330 612 0015	32.0	26.2	2332 612 0015
	1.5 - 3.0	16.0	20.0	2.0	S = 5.4-e	24.6	17.2	2330 612 0030	33.6	26.2	2332 612 0030
	3.0 - 4.5	16.0	20.0	2.0	S = 7.0-e	26.2	17.2	2330 612 0045	35.2	26.2	2332 612 0045
M12	4.5 - 6.0	16.0	20.0	2.0	S = 8.6-e	27.8	17.2	2330 612 0060	36.8	26.2	2332 612 0060

* Dimensions S and L₂ are indicative values. The difference in length S depends on the material thickness and is used as the setting tool stroke. Dimensions in mm. Other dimensions and variants can be supplied on request.

RIVKLE® steel

RIVKLE® stainless steel

RIVKLE® aluminium

RIVKLE® HRT

RIVKLE® PN
RIVKLE® Elastic

RIVKLE® blind rivet
studs, steel

Special designs

RIVKLE® Stainless steel blind rivet nuts

Round body, linear knurls in grip range, countersunk head

Types 2331 6 open and 2333 6 closed

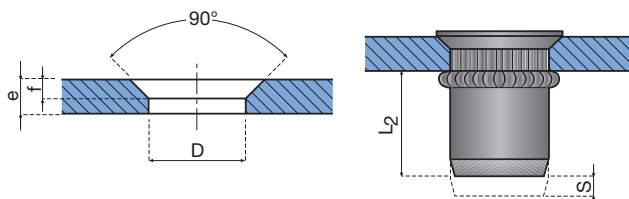
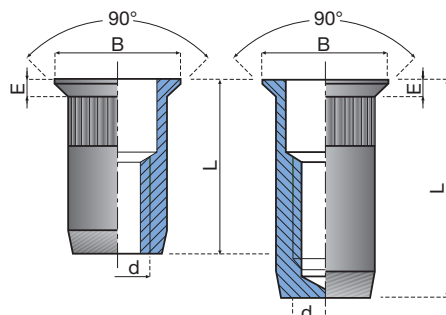
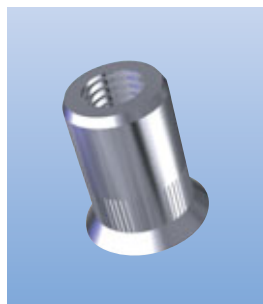

- Increased turning resistance
- Suitable for soft components (aluminium, plastic,...)
- Very small head projection
- High crimping force
- High corrosion resistance
- Screw length can be varied (open end)
- Splash-proof (closed end)
- Suitable for use in the food processing industry

d	Thickness e	Hole D ^{+0,1/0}	f	B	E	S*	Open			Closed		
							L	L ₂ *	Product code	L	L ₂ *	Product code
M3	1.3 – 2.0	5	0.9	7	1	S = 2.9-e	8.8	5.9	2331 603 0020	13.1	10.2	2333 603 0020
	2.0 – 3.0	5	0.9	7	1	S = 4.0-e	9.9	5.9	2331 603 0030	14.2	10.2	2333 603 0030
M4	1.3 – 2.0	6	0.9	8	1	S = 3.1-e	9.3	6.2	2331 604 0020	14.3	11.2	2333 604 0020
	2.0 – 3.0	6	0.9	8	1	S = 4.1-e	10.3	6.2	2331 604 0030	15.3	11.2	2333 604 0030
	3.0 – 4.0	6	0.9	8	1	S = 5.2-e	11.4	6.2	2331 604 0040	16.4	11.2	2333 604 0040
M5	1.5 – 2.0	7	0.9	9	1	S = 3.4-e	11.3	7.9	2331 605 0020	17.3	13.9	2333 605 0020
	2.0 – 3.0	7	0.9	9	1	S = 4.5-e	12.3	7.8	2331 605 0030	18.3	13.8	2333 605 0030
	3.0 – 4.0	7	0.9	9	1	S = 5.6-e	13.4	7.8	2331 605 0400	19.4	13.8	2333 605 0400
M6	1.5 – 3.0	9	0.9	11	1	S = 4.7-e	13.3	8.6	2331 606 0030	18.3	13.6	2333 606 0030
	3.0 – 4.0	9	0.9	11	1	S = 5.8-e	14.3	8.5	2331 606 0040	19.3	13.5	2333 606 0040
	4.0 – 5.0	9	0.9	11	1	S = 6.9-e	15.4	8.5	2331 606 0050	20.4	13.5	2333 606 0050
	5.0 – 6.0	9	0.9	11	1	S = 8.0-e	16.5	8.5	2331 606 0060	21.5	13.5	2333 606 0060
M8	1.5 – 3.0	11	1.4	14	1.5	S = 4.8-e	15.3	10.5	2331 608 0030	21.3	16.5	2333 608 0030
	3.0 – 4.0	11	1.4	14	1.5	S = 5.8-e	16.3	10.5	2331 608 0040	22.3	16.5	2333 608 0040
	4.0 – 5.0	11	1.4	14	1.5	S = 6.9-e	17.4	10.5	2331 608 0050	23.4	16.5	2333 608 0050
	5.0 – 6.0	11	1.4	14	1.5	S = 8.0-e	18.5	10.5	2331 608 0060	24.5	16.5	2333 608 0060
M10	1.5 – 3.0	13	1.4	16	1.5	S = 5.5-e	19.4	13.9	2331 610 0030	27.4	21.9	2333 610 0030
	3.0 – 4.5	13	1.4	16	1.5	S = 7.1-e	21.0	13.9	2331 610 0045	29.0	21.9	2333 610 0045
	4.5 – 6.0	13	1.4	16	1.5	S = 8.7-e	22.6	13.9	2331 610 0060	30.6	21.9	2333 610 0060
M12	1.5 – 3.0	16	1.4	19	1.5	S = 5.4-e	22.6	17.2	2331 612 0030	31.6	26.2	2333 612 0030
	3.0 – 4.5	16	1.4	19	1.5	S = 7.0-e	24.2	17.2	2331 612 0045	33.2	26.2	2333 612 0045
	4.5 – 6.0	16	1.4	19	1.5	S = 8.6-e	25.8	17.2	2331 612 0060	34.8	26.2	2333 612 0060

* Dimensions S and L₂ are indicative values. The difference in length S depends on the material thickness and is used as the setting tool stroke.

Note: Countersink angle 90°. The optimum countersink depth f is slightly less than E.

Dimensions in mm.

Other dimensions and variants can be supplied on request.

RIVKLE® Stainless steel blind rivet nuts

Round body, plain, extra-small countersunk head

Type 3430 8 for holes with imperial dimensions
and type 3436 8 for holes with metric dimensions

Advantages:

- Very small head projection without countersinking
- High corrosion resistance
- Screw length can be varied
- Suitable for use in the food processing industry

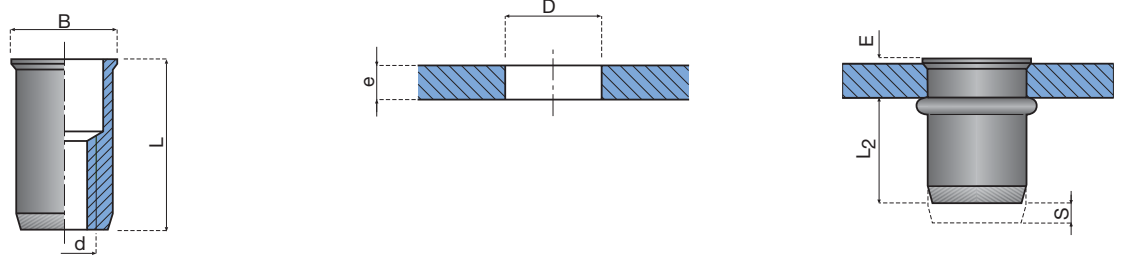

For a newly developed application we recommend the use of type 3436 8 for holes with metric dimensions.

Typ 3430 8

d	Thickness e	Hole D ^{+0.1/0}	B	E _{max.}	S*	L	L ₂ *	Product code
M3	0.5 – 1.5	4.7	5.2	0.4	S = 2.8-e	8.4	5.5	3430 803 0150
M4	0.5 – 2.0	6.4	6.7	0.5	S = 3.5-e	10.4	7.3	3430 804 0200
M5	0.5 – 3.0	7.1	7.7	0.6	S = 4.5-e	11.6	7.3	3430 805 0300
M6	0.7 – 3.0	9.5	10.2	0.6	S = 5.7-e	14.5	9.3	3430 806 0300
M8	0.7 – 3.0	10.5	11.3	0.7	S = 5.7-e	16.8	10.5	3430 808 0300

Typ 3436 8

d	Thickness e	Hole D ^{+0.1/0}	B	E _{max.}	S*	L	L ₂ *	Product code
M4	0.5 – 1.5	6	7	0.5	S = 3.0-e	10	6.5	3436 804 0015
M5	0.5 – 2.0	7	8	0.6	S = 4.5-e	12	7.0	3436 805 0020
M6	0.7 – 3.0	9	10	0.6	S = 5.0-e	14	8.5	3436 806 0030
M8	0.7 – 3.0	11	12	0.7	S = 5.0-e	16	10.5	3436 808 0030

* Dimensions S and L₂ are indicative values. The difference in length S depends on the material thickness and is used as the setting tool stroke.

Dimensions in mm.

Other dimensions and variants can be supplied on request.

RIVKLE® steel

RIVKLE® stainless steel

RIVKLE® aluminium

RIVKLE® HRT

RIVKLE® PN
RIVKLE® Elastic

RIVKLE® blind rivet
studs, steel

Special designs

RIVKLE® Stainless steel blind rivet nuts

Round body, linear knurls in grip range, with extra-small countersunk head

Types 3436 6 open and 3437 6 closed

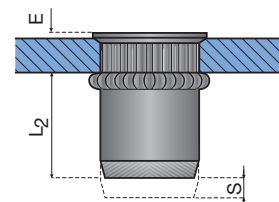
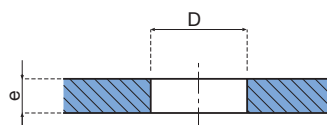
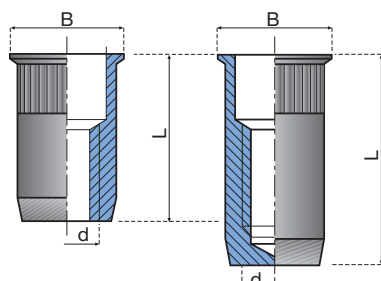

- Very small head projection without countersinking
- Suitable for soft components (aluminium, plastic,...)
- High corrosion resistance
- Screw length can be varied (open end)
- Splash-proof (closed end)
- Suitable for use in the food processing industry

d	Thickness e	Hole D ^{+0.1/0}	B	E _{max}	S*	Open			Closed		
						L	L ₂ *	Product code.	L	L ₂ *	Product code
M3	0.7 – 1.5	5.0	6.0	0.4	S = 2.4-e	8.7	5.9	3436 603 0015	13.0	10.2	3437 603 0015
	1.5 – 2.5	5.0	6.0	0.4	S = 3.5-e	9.8	5.9	3436 603 0025	14.1	10.2	3437 603 0025
M4	0.7 – 3.3	6.0	7.0	0.5	S = 4.0-e	11.6	7.0	3436 604 0233	/	/	/
	0.7 – 1.5	6.0	7.0	0.4	S = 2.5-e	/	/	/	14.8	11.9	3437 604 0015
	1.5 – 2.5	6.0	7.0	0.4	S = 3.6-e	/	/	/	15.6	11.6	3437 604 0025
	2.5 – 3.5	6.0	7.0	0.4	S = 4.7-e	11.7	6.6	3436 604 0035	16.7	11.6	3437 604 0035
M5	0.7 – 3.3	7.0	8.0	0.5	S = 5.3-e	12.3	7.2	3436 605 0233	/	/	/
	0.8 – 2.0	7.0	8.0	0.4	S = 3.2-e	/	/	/	17.8	14.2	3437 605 0020
	2.0 – 3.0	7.0	8.0	0.4	S = 4.3-e	/	/	/	18.9	14.2	3437 605 0030
	3.0 – 4.0	7.0	8.0	0.4	S = 5.4-e	14.0	8.2	3436 605 0040	20.0	14.2	3437 605 0040
M6	0.7 – 3.3	9.0	10.0	0.6	S = 5.7-e	14.5	8.6	3436 606 0233	/	/	/
	0.8 – 1.5	9.0	10.0	0.5	S = 3.1-e	/	/	/	17.3	13.7	3437 606 0015
	1.5 – 3.0	9.0	10.0	0.5	S = 4.7-e	/	/	/	18.8	13.6	3437 606 0030
	3.0 – 4.5	9.0	10.0	0.5	S = 6.3-e	15.4	8.6	3436 606 0045	20.4	13.6	3437 606 0045
	4.5 – 6.0	9.0	10.0	0.5	S = 7.9-e	17.0	8.6	3436 606 0060	22.0	13.6	3437 606 0060
M8	0.7 – 3.3	11.0	12.0	0.6	S = 6.5-e	16.1	9.5	3436 608 0233	/	/	/
	0.8 – 1.5	11.0	12.0	0.5	S = 3.1-e	/	/	/	20.3	16.7	3437 608 0015
	1.5 – 3.0	11.0	12.0	0.5	S = 4.7-e	/	/	/	21.9	16.7	3437 608 0030
	3.0 – 4.5	11.0	12.0	0.5	S = 6.3-e	17.5	10.7	3436 608 0045	23.5	16.7	3437 608 0045
	4.5 – 6.0	11.0	12.0	0.5	S = 7.9-e	19.1	10.7	3436 608 0060	25.1	16.7	3437 608 0060
M10	0.8 – 1.5	13.0	14.0	0.5	S = 3.9-e	18.3	13.9	3436 610 0015	26.3	21.9	3437 610 0015
	1.5 – 3.0	13.0	14.0	0.5	S = 5.5-e	19.9	13.9	3436 610 0030	27.9	21.9	3437 610 0030
	3.0 – 4.5	13.0	14.0	0.5	S = 7.1-e	21.5	13.9	3436 610 0045	29.5	21.9	3437 610 0045
	4.5 – 6.0	13.0	14.0	0.5	S = 8.7-e	23.1	13.9	3436 610 0060	31.1	21.9	3437 610 0060
M12	0.8 – 1.5	16.0	17.0	0.5	S = 3.8-e	21.5	17.2	3436 612 0015	30.5	26.2	3437 612 0015
	1.5 – 3.0	16.0	17.0	0.5	S = 5.4-e	23.1	17.2	3436 612 0030	32.1	26.2	3437 612 0030
	3.0 – 4.5	16.0	17.0	0.5	S = 7.0-e	24.7	17.2	3436 612 0045	33.7	26.2	3437 612 0045
	4.5 – 6.0	16.0	17.0	0.5	S = 8.6-e	26.3	17.2	3436 612 0060	35.3	26.2	3437 612 0060

* Dimensions S and L₂ are indicative values. The difference in length S depends on the material thickness and is used as the setting tool stroke. Dimensions in mm.

Other dimensions and variants can be supplied on request.

RIVKLE® Stainless steel blind rivet nuts

Hexagonal body, flat head

Typ 2334 8

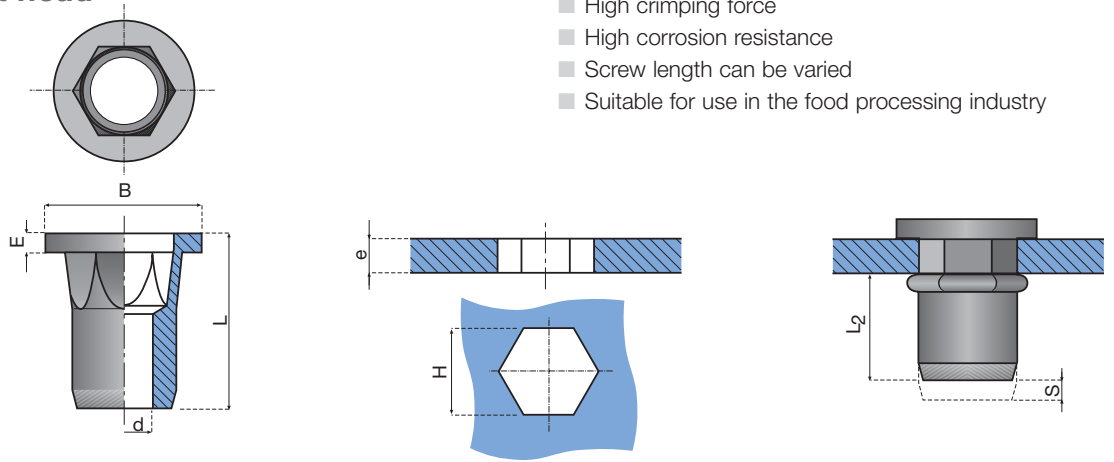

Advantages:

- Very high turning resistance
- Suitable for soft components (aluminium, plastic,...)
- High crimping force
- High corrosion resistance
- Screw length can be varied
- Suitable for use in the food processing industry

d	Thickness e	Hole $H^{+0.1/0}$	B	E	S*	L	L ₂ *	Product code
M4	0.5 – 2.0	6	9	1.0	S = 4.1-e	10.5	5.4	2334 804 0001
M5	0.5 – 3.0	7	10	1.0	S = 5.0-e	14.0	8.0	2334 805 0001
M6	0.5 – 3.0	9	11	1.5	S = 4.5-e	16.0	10.0	2334 806 0001
M8	0.7 – 3.0	11	14	1.5	S = 5.5-e	18.0	11.0	2334 808 0001

* Dimensions S and L₂ are indicative values. The difference in length S depends on the material thickness and is used as the setting tool stroke.

Dimensions in mm. Other dimensions and variants can be supplied on request.

RIVKLE® steel

RIVKLE® stainless steel

RIVKLE® aluminium

RIVKLE® HRT

RIVKLE® PN
RIVKLE® Elastic

RIVKLE® blind rivet
studs, steel

Special designs

RIVKLE® Stainless steel blind rivet nuts

Hexagonal body, extra-small countersunk head

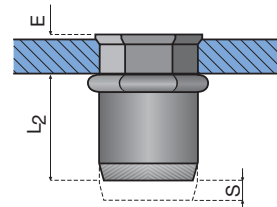
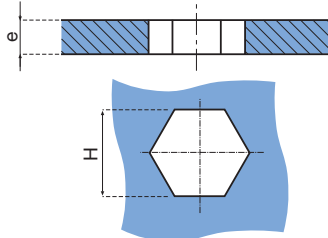
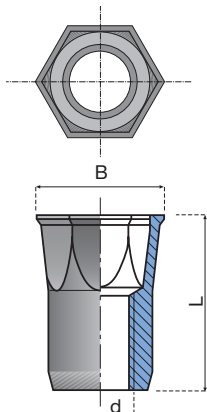
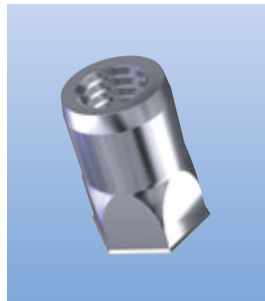

Advantages:

- Very high turning resistance
- Suitable for soft components (aluminium, plastic,...)
- Very small head projection without countersinking
- High corrosion resistance
- Screw length can be varied
- Suitable for use in the food processing industry

Type 3434 8

d	Thickness e	Hole H ^{+0.1/0}	B	E _{max}	S*	L	L ₂ *	Product code
M4	0.5 – 2.0	6	7.3	0.5	S = 3.1-e	10.4	6.8	3434 804 0020
M4	2.0 – 3.0	6	7.3	0.5	S = 4.2-e	12.0	6.8	3434 804 0030
M5	0.5 – 3.0	7	8.4	0.6	S = 4.4-e	12.0	7.0	3434 805 0020
M6	0.5 – 3.0	9	10.6	0.6	S = 4.2-e	14.5	9.5	3434 806 0025
M8	0.8 – 3.0	11	13.0	0.7	S = 4.7-e	15.8	10.0	3434 808 0030
M10	1.0 – 3.5	13	15.0	0.9	S = 8.0-e	19.4	12.0	3434 810 0035

* Dimensions S and L₂ are indicative values. The difference in length S depends on the material thickness and is used as the setting tool stroke.

Dimensions in mm. Other dimensions and variants can be supplied on request.

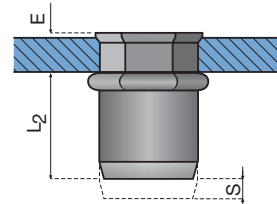
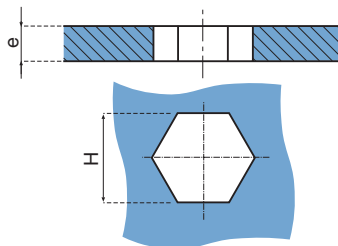
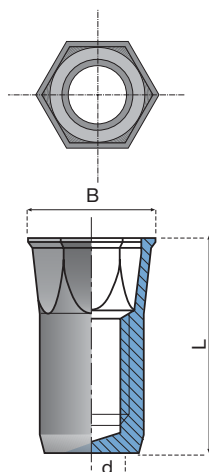
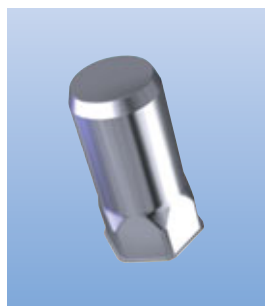

Advantages:

- Very high turning resistance
- Suitable for soft components (aluminium, plastic,...)
- Very small head projection without countersinking
- High corrosion resistance
- Screw length can be varied
- Suitable for use in the food processing industry

Type 3435 8 closed

d	Thickness e	Hole H ^{+0.1/0}	B	E _{max}	S*	L	L ₂ *	Product code
M4	0.5 – 2.5	6	7.3	0.5	S = 3.8-e	15.4	11.5	3435 804 0025
M5	0.5 – 3.0	7	8.4	0.6	S = 4.4-e	17.5	12.5	3435 805 0020
M6	0.5 – 3.0	9	10.6	0.6	S = 4.2-e	20.5	15.0	3435 806 0030

* Dimensions S and L₂ are indicative values. The difference in length S depends on the material thickness and is used as the setting tool stroke.

Dimensions in mm. Other dimensions and variants can be supplied on request.

RIVKLE® Stainless steel blind rivet nuts

Hexagonal body, extra-small countersunk head and optimised head projection

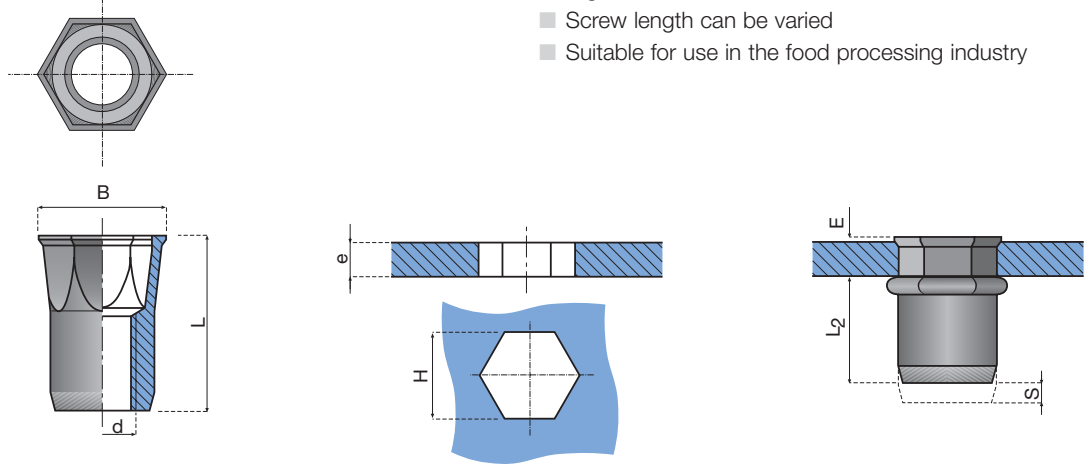

Type 3439 8 open

d	Thickness e	Hole $H^{+0.1/0}$	B	E_{max}	S*	L	L_2^*	Product code
M4	0.8 – 3.0	6	7.3	0.3	S = 4.2-e	11.3	6.8	3439 804 0627
M5	0.5 – 3.0	7	8.4	0.3	S = 4.4-e	11.8	7.0	3439 805 0622
M6	0.5 – 3.0	9	10.6	0.3	S = 4.2-e	14.3	9.7	3439 806 0624
M8	0.8 – 3.0	11	13.0	0.6	S = 4.7-e	15.6	10.0	3439 808 0625

* Dimensions S and L_2 are indicative values. The difference in length S depends on the material thickness and is used as the setting tool stroke.

Dimensions in mm. Other dimensions and variants can be supplied on request.

Advantages:

- Very high turning resistance
- Suitable for soft components (aluminium, plastic,...)
- Very small head projection without countersinking
- High corrosion resistance
- Screw length can be varied
- Suitable for use in the food processing industry

RIVKLE® steel

RIVKLE® stainless steel

RIVKLE® aluminium

RIVKLE® HRT

RIVKLE® PN
RIVKLE® Elastic

RIVKLE® blind rivet
studs, steel

Special designs

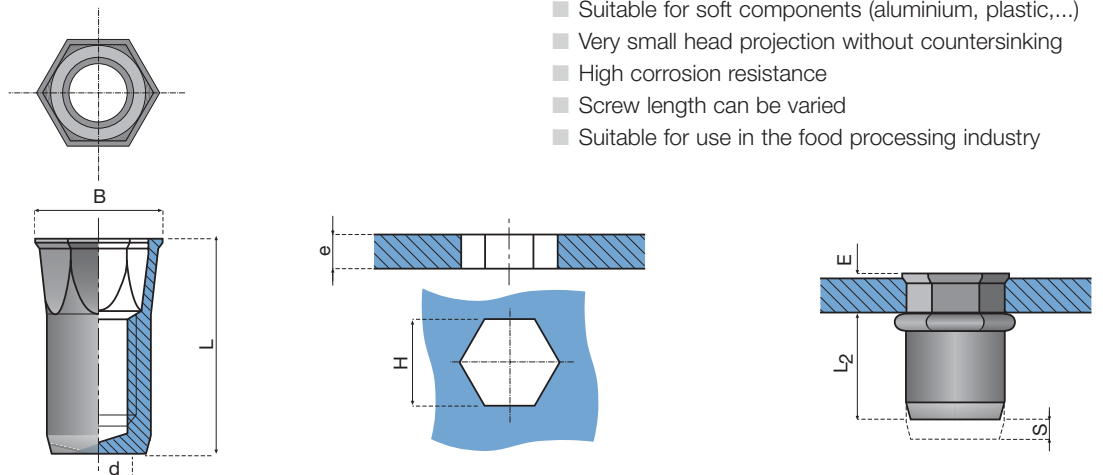
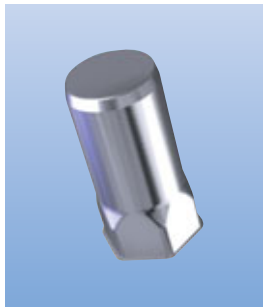

Type 3439 8 closed

d	Thickness e	Hole $H^{+0.1/0}$	B	E_{max}	S*	L	L_2^*	Product code
M4	1.0 – 3.0	6	7.3	0.3	S = 4.7-e	16.1	11.9	3439 804 0628
M5	1.0 – 3.5	7	8.4	0.3	S = 5.5-e	18.7	13.6	3439 805 0628
M6	1.0 – 3.5	9	10.6	0.3	S = 5.2-e	22.5	15.0	3439 806 0628

* Dimensions S and L_2 are indicative values. The difference in length S depends on the material thickness and is used as the setting tool stroke.

Dimensions in mm. Other dimensions and variants can be supplied on request.

RIVKLE® Aluminium blind rivet nuts

Round body, plain, flat head

Types 2330 0 open and 2332 0 closed

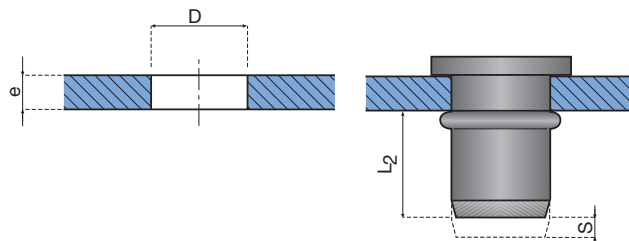
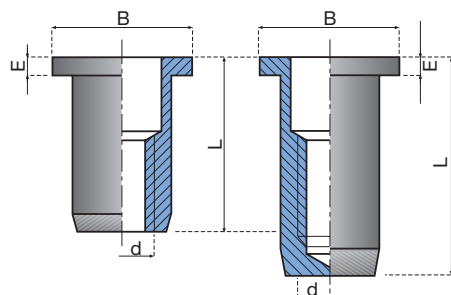

- High crimping force
- Lightweight
- High corrosion resistance
- Screw length can be varied (open end)
- Splash-proof (closed end)

d	Thickness e	Hole D ^{+0.1/0}	B	E	S*	Open			Closed		
						L	L ₂ *	Product code	L	L ₂ *	Product code
M3	0.25 – 2.00	5	7.5	1.0	S = 3.0-e	9.6	5.4	2330 003 0020	13.5	9.3	2332 003 0020
	2.00 – 3.50	5	7.5	1.0	S = 4.5-e	11.2	5.4	2330 003 0035	15.1	9.3	2332 003 0035
M4	0.25 – 2.50	6	9.0	1.0	S = 4.1-e	11.0	6.3	2330 004 0025	16.0	11.3	2332 004 0025
	2.50 – 4.50	6	9.0	1.0	S = 6.1-e	13.1	6.3	2330 004 0045	18.1	11.3	2332 004 0045
M5	0.25 – 3.00	7	10.0	1.0	S = 4.5-e	13.6	7.8	2330 005 0030	19.3	13.5	2332 005 0030
	3.00 – 5.50	7	10.0	1.0	S = 7.0-e	16.2	7.8	2330 005 0055	21.9	13.5	2332 005 0055
M6	0.50 – 3.00	9	13.0	1.5	S = 5.0-e	16.6	10.4	2330 006 0030	23.6	17.4	2332 006 0030
	3.00 – 5.50	9	13.0	1.5	S = 7.5-e	19.3	10.4	2330 006 0055	26.3	17.4	2332 006 0055
M8	0.50 – 3.00	11	16.0	1.5	S = 6.0-e	20.0	12.7	2330 008 0030	28.3	21.0	2332 008 0030
	3.00 – 5.50	11	16.0	1.5	S = 8.5-e	22.7	12.7	2330 008 0055	31.0	21.0	2332 008 0055
M10	0.80 – 3.50	13	19.0	2.0	S = 6.5-e	25.0	16.6	2330 010 0035	34.9	26.5	2332 010 0035
	3.50 – 6.00	13	19.0	2.0	S = 9.0-e	27.7	16.6	2330 010 0060	37.6	26.5	2332 010 0060
M12	0.50 – 1.50	16	23.0	2.0	S = 4.5-e	26.2	20.0	2330 012 0150	37.7	31.5	2332 012 0150
	1.50 – 3.00	16	23.0	2.0	S = 6.0-e	27.8	20.0	2330 012 0300	39.3	31.5	2332 012 0300
	3.00 – 4.50	16	23.0	2.0	S = 7.5-e	29.4	20.0	2330 012 0450	40.9	31.5	2332 012 0450
	4.50 – 6.00	16	23.0	2.0	S = 9.0-e	31.0	20.0	2330 012 0600	42.5	31.5	2332 012 0600

* Dimensions S and L₂ are indicative values. the difference in length S depends on the material thickness and is used as the setting tool stroke. Dimensions in mm.

Other dimensions and variants can be supplied on request.

RIVKLE® Aluminium blind rivet nuts

Round body, plain, countersunk head

Types 2331 0 open and 2333 0 closed

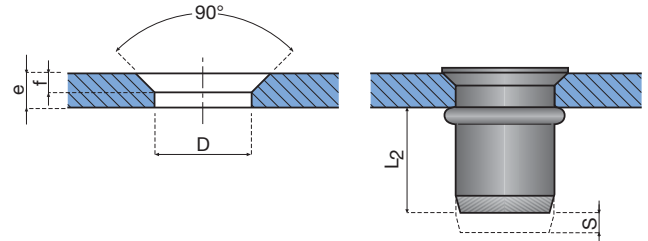
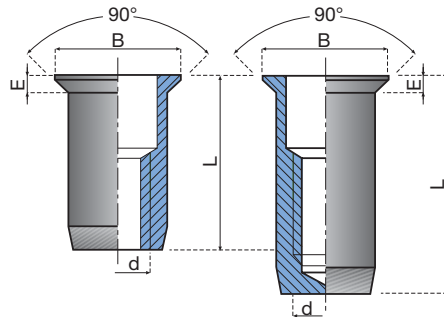

d	Thickness e	Hole D ^{+0.1/0}	f	B	E	S*	Open			Closed		
							L	L ₂ *	Product code	L	L ₂ *	Product code
M3	1.50 – 3.50	5	1.3	7.2	1.4	S = 4.5-e	10.2	5.6	2331 003 0035	14.1	9.5	2333 003 0035
	3.50 – 5.00	5	1.3	7.2	1.4	S = 6.0-e	11.8	5.6	2331 003 0050	15.7	9.5	2333 003 0050
M4	1.50 – 3.50	6	1.3	8.2	1.4	S = 4.8-e	11.3	6.5	2331 004 0035	16.3	11.5	2333 004 0035
	3.50 – 5.00	6	1.3	8.2	1.4	S = 6.3-e	12.9	6.5	2331 004 0050	17.9	11.5	2333 004 0050
M5	1.50 – 4.50	7	1.5	9.6	1.6	S = 6.0-e	14.2	7.8	2331 005 0045	19.4	13.5	2333 005 0045
	4.50 – 6.50	7	1.5	9.6	1.6	S = 8.0-e	16.3	7.8	2331 005 0065	22.0	13.5	2333 005 0065
M6	1.50 – 4.50	9	1.5	11.7	1.6	S = 6.3-e	16.6	10.4	2331 006 0045	23.6	17.4	2333 006 0045
	4.50 – 6.50	9	1.5	11.7	1.6	S = 8.3-e	18.7	10.4	2331 006 0065	25.7	17.4	2333 006 0065
M8	1.50 – 4.50	11	1.5	13.5	1.6	S = 7.5-e	20.1	12.7	2331 008 0045	28.4	21.0	2333 008 0045
	4.50 – 6.50	11	1.5	13.5	1.6	S = 9.5-e	22.2	12.7	2331 008 0065	30.5	21.0	2333 008 0065
M10	1.50 – 4.50	13	1.5	15.5	1.6	S = 7.5-e	24.0	16.6	2331 010 0045	33.9	26.5	2333 010 0045
	4.50 – 6.50	13	1.5	15.5	1.6	S = 9.5-e	26.1	16.6	2331 010 0065	36.0	26.5	2333 010 0065
M12	1.70 – 3.00	16	1.7	19.0	1.8	S = 6.0-e	25.8	20.0	2331 012 0300	37.3	31.5	2333 012 0300
	3.00 – 4.50	16	1.7	19.0	1.8	S = 7.5-e	27.4	20.0	2331 012 0450	38.9	31.5	2333 012 0450
	4.50 – 6.00	16	1.7	19.0	1.8	S = 9.0-e	29.0	20.0	2331 012 0600	40.5	31.5	2333 012 0600

* Dimensions S and L₂ are indicative values. The difference in length S depends on the material thickness and is used as the setting tool stroke. Note: Countersink angle 90°. The optimum countersink depth f is slightly less than E.

Dimensions in mm.

Other dimensions and variants can be supplied on request.

Advantages:

- Very small head projection
- High crimping force
- High corrosion resistance
- Lightweight
- Screw length can be varied (open end)
- Splash-proof (closed end)

RIVKLE® steel

RIVKLE® stainless steel

RIVKLE® aluminium

RIVKLE® HRT

RIVKLE® PN
RIVKLE® Elastic

RIVKLE® blind rivet
studs, steel

Special designs

RIVKLE® HRT Steel

Advantages of RIVKLE® HRT

In comparison to standard RIVKLE® blind rivet nuts:

- Increased tightening torque enables higher tension in the assembly
- Permits use of smaller dimensions
- Weight saving

Compared to others technologies:

- Blind fitting from one side only
- Automatic assembly options to reduce cycle time
- Automation of setting for 'difficult-to-access' locations on the assembly line
- Low investment
- Integration of assembly station into a volume production line
- No rework of threads required after assembly/painting
- 100 % controlled assembly is possible

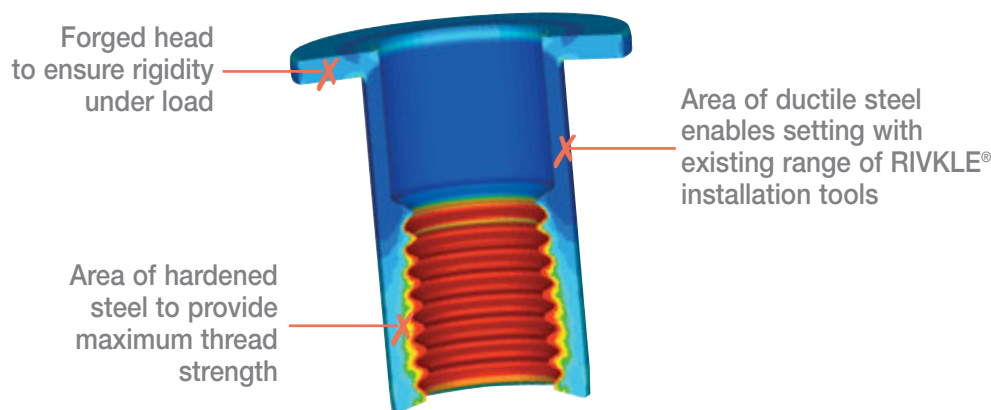

Product development of our existing RIVKLE® technology has resulted in our patented HRT process (**H**igh **R**esistance **T**hread) which uses advanced materials and processes to produce an enhanced, hardened, thread which significantly increases the mechanical performance of the blind rivet nut.

A lightweight, simple to install solution which allows use of fasteners up to and including grade 12.9 making it ideal for structural applications requiring higher joint tension and mechanical forces within the assembly.

Steel performances - Strength grade 12

The maximum acceptable tightening torque of a screw/nut assembly determines the preload developed in the joint. These values have been established in the standard ISO-898-1 / ISO-898-2(1) and require that in such a screwed joint it is desirable that when fatigue occurs the screw fails before the nut.

As the preload in an assembly increases so the use of progressively higher strength fasteners is necessary. The table below shows the compatibility of steel **RIVKLE® HRT** with screws of grade 12.9.

Thread diameter	Screw grade 12.9 / Nut grade 12 (N) ISO 898-1 / ISO 898-2		RIVKLE® HRT (N)
	Proof load of the screw (1)	Proof load of the nut	Proof load
M 6	19 500	23 100	23 100
M 8	35 500	42 500	42 500
M 10	56 300	67 300	67 300
M 12	81 800	100 300	100 300

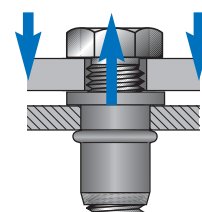

RIVKLE® HRT Steel

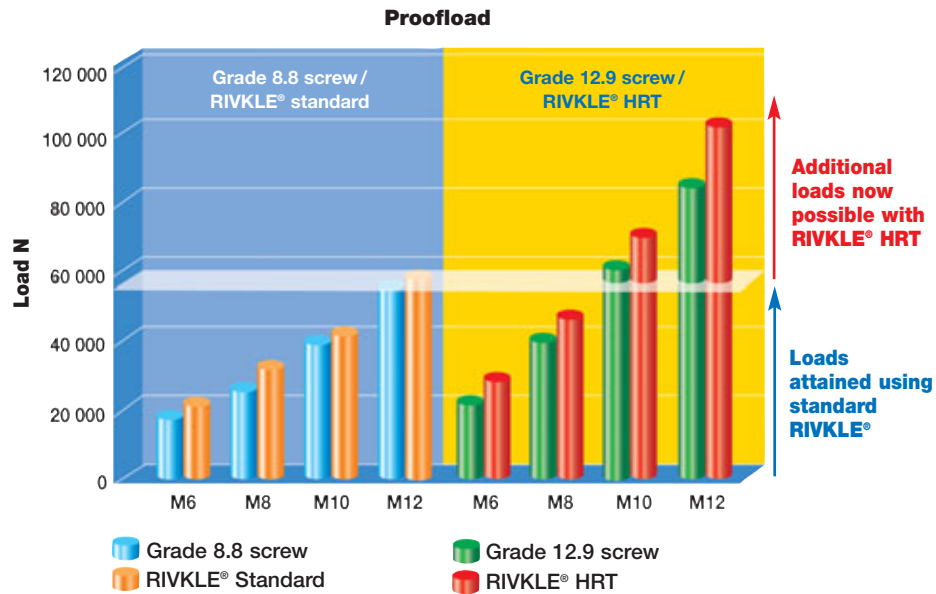

Technical features of RIVKLE® HRT Steel

- Material: Steel. A wide range of plating finishes are available including zinc or zinc nickel.
 - Size range: M 6 to M 12.
 - Body styles: **RIVKLE® HRT** is available only with an hexagonal body and flat head .
 - Special shapes are available on request.
- A/F and hole dimensions are shown in the table below and are interchangeable with standard RIVKLE® products.

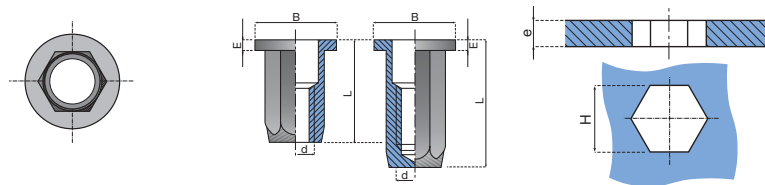

Thread diameter d	Grip range e	Hex Hole A/F H	Head diameter B	Head thickness E	Overall length L	Product code
M 6	1.0 – 3.0	9	14	1.5	18.6	2324 106 0030
M 8	1.0 – 3.0	11	17	1.5	23.6	2324 108 0030
M 10	1.0 – 3.5	13	20	2.0	27.0	2324 110 0035
M 12	1.0 – 4.0	16	24	2.0	33.0	2324 110 0040

Unit: mm

Applications

- **Use to replace traditional fastening methods for proof loads above 54 kN:**
Examples: to replace welded fasteners used on excavators, public works equipment and structural joints using M 10 and M 12 screws in grade 12.9.
- **Reducing dimensions and weight of fastenings:**
Example: for a fastening carrying a preload of 35 kN, the traditional solution was to use an M 12 screw in grade 8.8 with a corresponding nut.
Today you can replace this with an M 8 screw in grade 12.9. Assembled with an M 8 **RIVKLE® HRT** blind rivet nut to carry the same load.

RIVKLE® steel

RIVKLE® stainless steel

RIVKLE® aluminium

RIVKLE® HRT

RIVKLE® PN
RIVKLE® Elastic

RIVKLE® blind rivet
studs, steel

Special designs

RIVKLE® HRT Aluminium

Advantages of RIVKLE® HRT

In comparison to standard RIVKLE® blind rivet nuts:

- Increased tightening torque enables higher tension in the assembly
- Permits use of smaller dimensions
- Weight saving
- Corrosion resistance

Compared to others technologies:

- Blind fitting from one side only
- Automatic assembly options to reduce cycle time
- Automation of setting for 'difficult-to-access' locations on the assembly line
- Low investment
- Ability to completely recycle aluminium products
- Integration of assembly station into a volume production line
- No rework of threads required after assembly / painting
- 100 % controlled assembly is possible

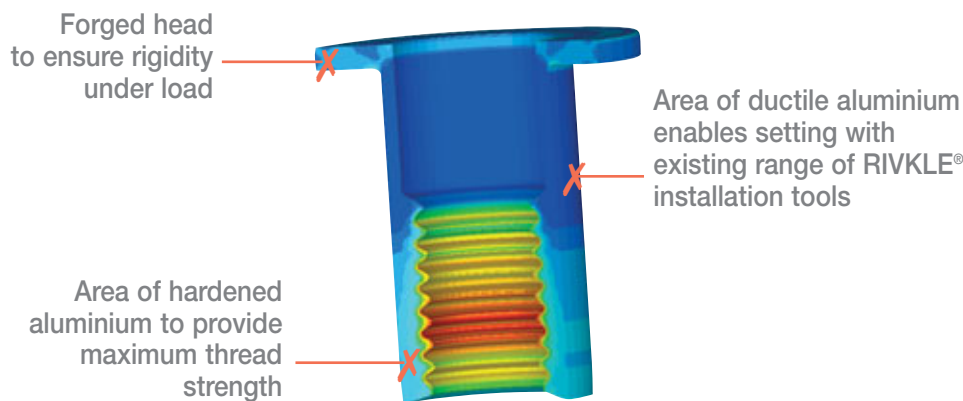

RIVKLE® HRT produced in aluminium is a combination of lightweight material and inherent strength. The ability to recycle fastenings is important in the design concept of many products; use of RIVKLE® HRT aluminium provides the many advantages of an aluminium fastening but is now combined with the strength required to be compatible with grade 8.8 screws. Highly corrosion resistant, this blind rivet nut can be used in aluminium, plastic or coated steel sheets for external applications.

Aluminium performances – Strength grade 8

The maximum acceptable tightening torque of a screw/nut assembly determines the preload developed in the joint.

These values have been established in the standard ISO-898-1/ ISO-898-2 (1) and require that in such a screwed joint it is desirable that when fatigue occurs the screw fails before the nut.

As the preload in an assembly increases so the use of progressively higher strength fasteners is necessary.

The table below shows the compatibility of **RIVKLE® HRT** aluminium with screws of grade 8.8.

Thread diameter	Screw grade 8.8 / Nut grade 8.8 (N) ISO 898-1 / ISO 898-2		RIVKLE® HRT (N)
	Proofload of the screw (1)	Proofload of the nut	Proofload
M 6	11 600	16 100	17 200
M 8	21 200	29 200	31 800

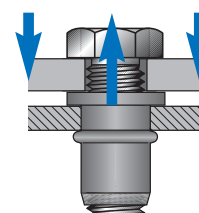

RIVKLE® HRT Aluminium

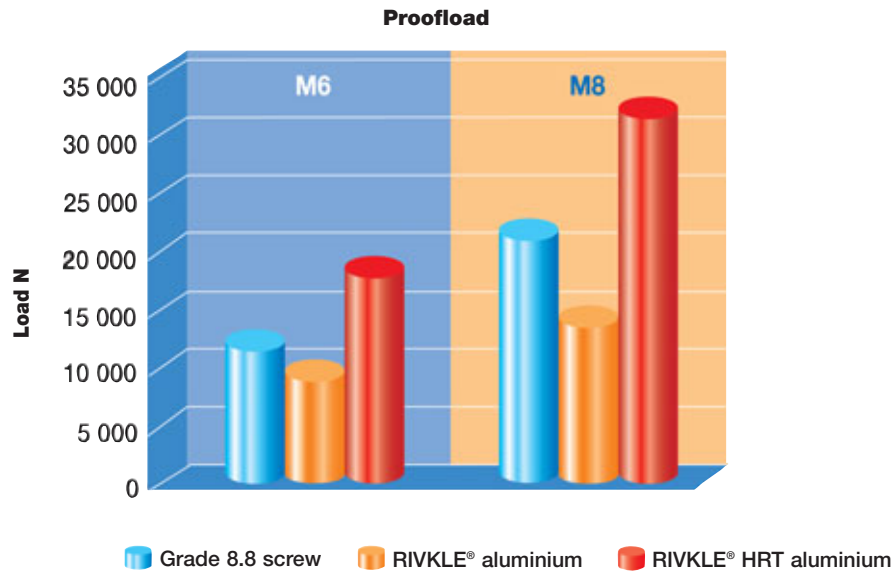

Aluminium RIVKLE® HRT technical features

- Material: aluminium 5056.
 - Size range: M 6 to M 8.
 - Body styles: **RIVKLE® HRT** is available only with an hexagonal body and flat head.
 - Special shapes are available on request.
- A/F and hole dimensions are shown in the table below and are interchangeable with standard RIVKLE® products.

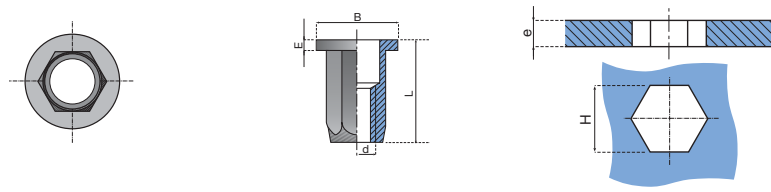

Thread diameter d	Grip range e	Hex Hole A/F H	Head diameter B	Head thickness E	Overall length L	Product code
M 6	0.5 – 3.0	9	14	1.5	18.6	2324 006 0030
M 8	0.5 – 3.0	11	17	1.5	23.6	2324 008 0030

Unit: mm

Applications

- **Weight saving RIVKLE® blind fastening compatible with screw grade 8.8:**
Example: directly replace an hexagonal M 6 nut with HRT and achieve a weight reduction of 63%.
 - **Corrosion resistant solution for external applications:**
Example: traffic signs; joining aluminium tubes on decorative architecture; replace expensive stainless steel fixings.
- High resistant and easy to recycle joints for mobile aluminium structures (car body construction, commercial vehicles, railed vehicles, ...)

RIVKLE® steel

RIVKLE® stainless steel

RIVKLE® aluminium

RIVKLE® HRT

RIVKLE® PN
RIVKLE® Elastic

RIVKLE® blind rivet
studs, steel

Special designs

RIVKLE® PN for ultimate pull-out force value

Blind rivet nuts of the RIVKLE® PN series have been specially designed for integrating into plastic parts, hollow sections or thin-walled sheet metal requiring high pull-out forces. The slotted shank splays out into four “petals” on the blind side of the base material, providing a large bearing surface and ensuring maximum pull-out force.

Additional design benefits of RIVKLE® PN series are:

- The RIVKLE® PN displays the largest clamping area of the range of blind rivet nuts for variable thickness of material
- Large clamping area to reinforce the workpiece
- Minimal radial stresses in the setting process to avoid too high stresses on the workpiece
- Available in steel (aluminium and stainless steel on request)
- Available in thread sizes M 5 to M 8 (other measurements on request)

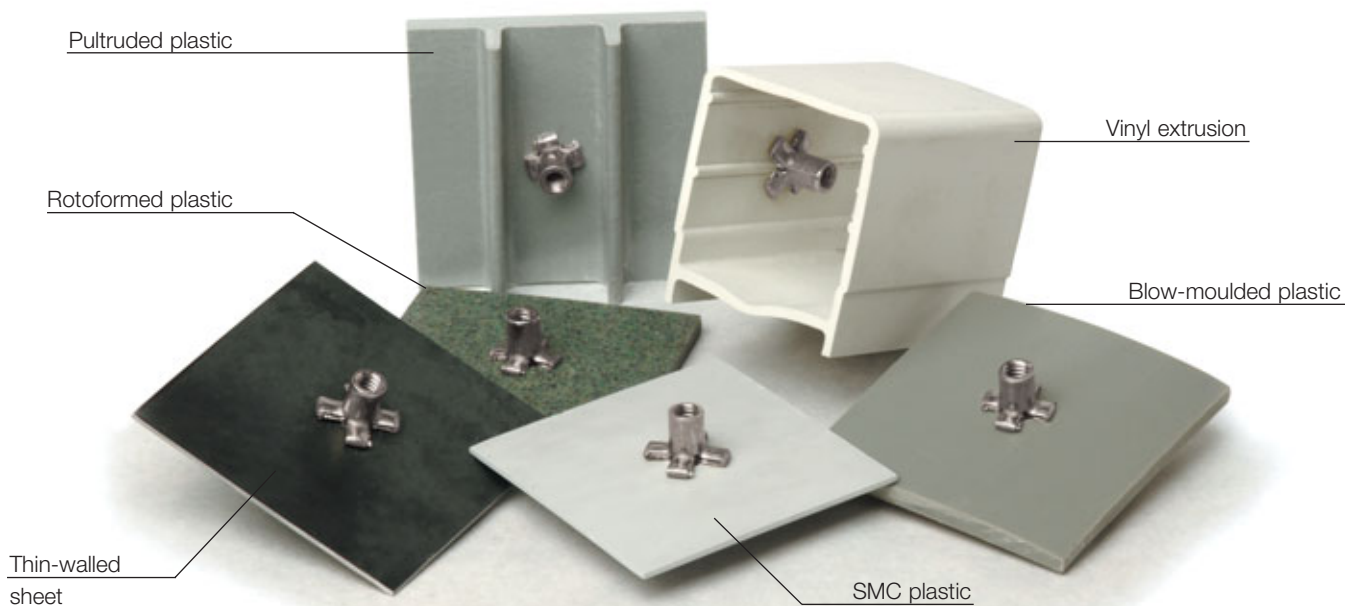

RIVKLE® PNP – Impressive pull-out resistance

The following table compares pull-out forces for the standard RIVKLE® blind rivet nut and the RIVKLE® PNP blind rivet nut of the measurement M 6 in the materials illustrated above.



Blind rivet nut type	0.76 mm steel	2.92 mm vinyl extrusion	6.29 mm pultruded plastic	3.04 mm rotoformed plastic	1.65 mm SMC plastic	4.69 mm blow-moulded plastic
RIVKLE®	2 130 N	900 N	6 760 N	100 N	600 N	1 250 N
RIVKLE® PNP	5 400 N	2 750 N	8 400 N	700 N	1 620 N	3 220 N

Note: Pull-out testing was conducted with a circular retaining plate, dia. 65 mm. Böllhoff recommends testing under actual application conditions in order to determine the exact pull-out force.

d	Setting load RIVKLE® PNP (N)	Proofload (N)	Max. tightening torque (Nm)
M 5	4 000	10 000	6
M 6	6 000	15 000	10
M 8	10 000	27 000	24

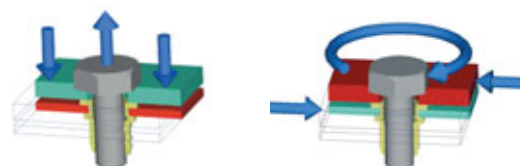

RIVKLE® PNP – Technical Data

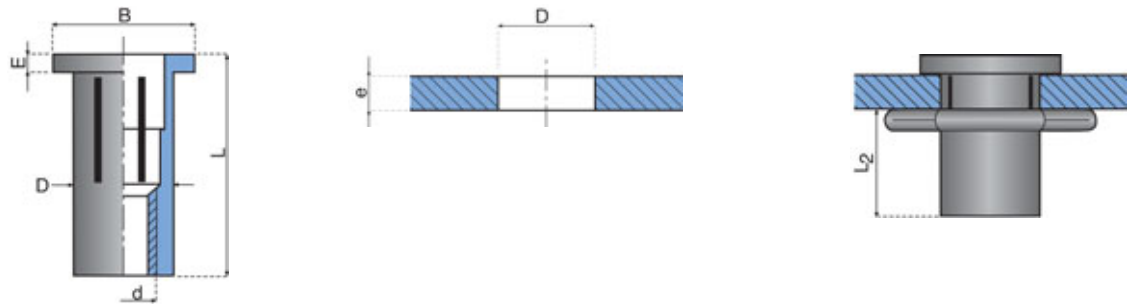

d	Clamping area e	Location hole		E	B	L	L ₂	Product code
		D _{min.}	D _{max.}					
M 5	0.5 – 3.0	7.48	7.62	0.96	12.7	22.0	9.9	6687 051 1030
M 6	0.5 – 5.0	8.80	8.93	1.50	15.9	26.9	12.8	6687 061 1050
M 8	0.5 – 5.0	11.11	11.50	1.57	19.0	30.5	14.5	6687 081 1050

Surface treatment: 8 µ zinc plated with iridescent passivate (Chrome(VI) free according ROHS directives and scrapped cars directives).
 Material: steel. Dimensions in mm. Thread tolerance: 6H. Other measurements and variants on request.

RIVKLE® PNB (pre-bulbed) on request

The RIVKLE®PNB blind rivet nut features all the functions and advantages of the standard design. In addition, thanks to its gentle pre-slaving, the riveting can be done by a rotating mandrel (e.g. by an assembly tool for screws). Assembly is also possible using a simple, inexpensive manual key mounting tool, which can be supplied alongside the RIVKLE®PNB.



RIVKLE® PN Blind rivet nuts with slotted shank, steel

The setting process: Four simple steps

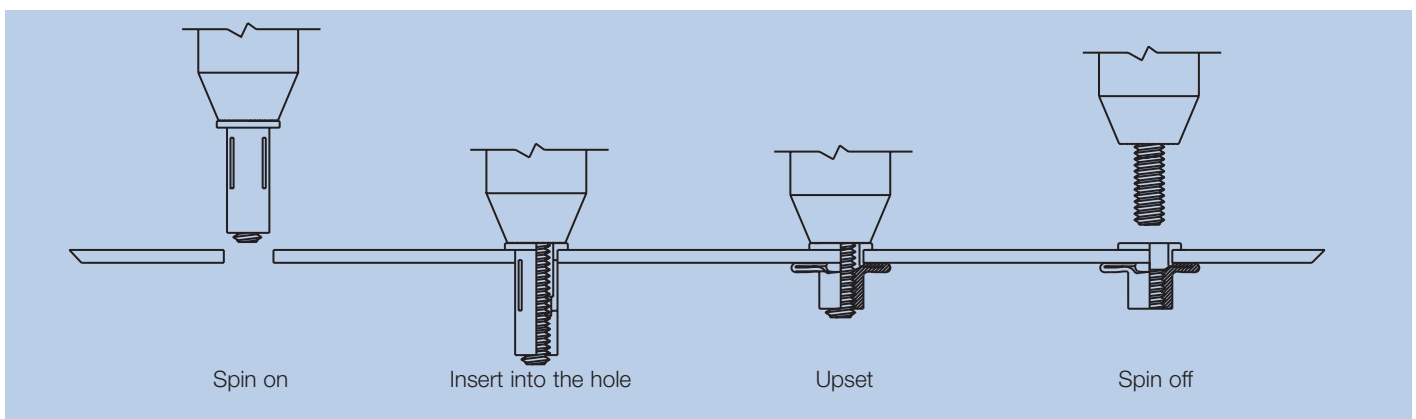

Special tools are required for setting RIVKLE® PNs. We will be happy to help you select the right riveting tool.

RIVKLE® steel

RIVKLE® stainless steel

RIVKLE® aluminium

RIVKLE® HRT

RIVKLE® PN
RIVKLE® Elastic

RIVKLE® blind rivet
studs, steel

Special designs

RIVKLE® Elastic – Blind rivet nuts for decoupling applications

The system

Our design specification was to produce a disconnectable blind rivet fastener with noise- and vibration decoupling characteristics.

Our solution is the RIVKLE® Elastic blind rivet nut.

The RIVKLE® Elastic blind rivet nut consists of a metric threaded metal insert captured in an elastomer or thermoplastic elastomer body.

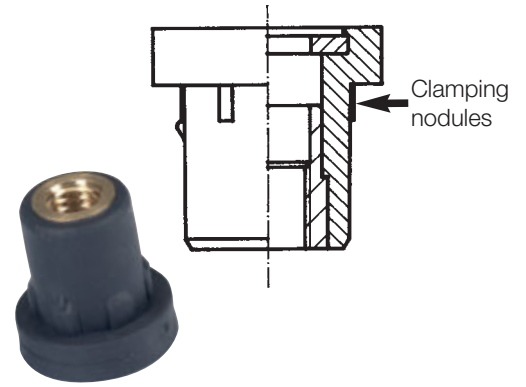

The principle

The RIVKLE® Elastic is an innovative solution for fastening load-bearing threaded inserts in thin-walled components and is ideal in applications where noise and vibration decoupling is also required.

The RIVKLE® Elastic is inserted into the pilot hole from one side of the carrier component.

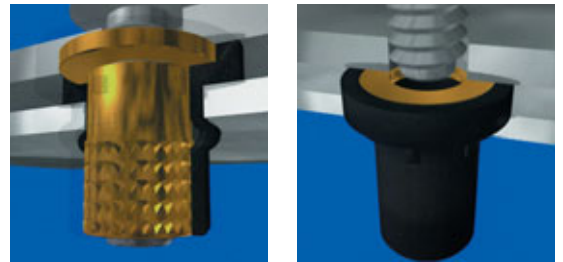

Clamping nodules beneath the flange secure the fastener in the workpiece prior to assembly. The threaded metal insert (brass on the standard version) is only attached to the body on its lower section so that when the mating screw is tightened this causes the nut body to bulge on the underside of the component to be fastened.

This is a reversible rivet fastening.

Versions – standard versions

The standard RIVKLE® Elastic is available in two basic versions.

- RIVKLE® Elastic with washer
- RIVKLE® Elastic without washer

Standard versions are available in four sizes: M 4, M 5, M 6 and M 8. Standard versions are available with various shank lengths, shank diameters, metal inserts, thread types, thread lengths, thread diameters, materials and colours. The metal inserts are also available in various materials and surface finishes.

If the component to be fastened is made from steel and has a pilot hole to DIN ISO 273 standard, a RIVKLE® Elastic without a washer should be used. If the component is made from plastic, aluminium or steel and has a slotted hole, a RIVKLE® Elastic with a washer should be used.

Versions – custom versions

In addition to the standard versions we can also manufacture special versions made to customer specifications.

Customers can choose a metal type for the insert which perfectly matches their fastening specifications and other requirements such as strength.

Customers can choose from a range of elastomers and thermoplastic elastomers to ensure that the soft fastener body has the continuous operating temperature, chemical resistance and insulation characteristics required.

RIVKLE® Elastic – Blind rivet nuts for decoupling applications

Fastener materials

■ **Metal insert and washer**

Standard versions have threaded inserts made from brass. Inserts made from other metals with different strength specifications are also available.
Metal insert bodies are available with all known surface finishes.

The soft part of the fastener is made from various types of elastomer or thermoplastic elastomer depending on the thermal, mechanical and media resistance characteristics required.

The washers on RIVKLE® Elastic fitted with washers are punched from brass and have a zinc-plated surface finish. Other types of washer are available.

■ **Thermoplastic elastomer body**

Thermoplastic elastomer bodies are made from TPE-V which has the following characteristics:

■ **TPE-V**

- Good mechanical properties in the temperature range -40° C to +120° C
- Good media resistance

Elastomer body

Two types of elastomer are used on RIVKLE® Elastic with elastomer bodies: VMQ and EPDM. Other types of elastomer (e.g. AEM and ECO) are also available.

■ **VMQ**

- Very good thermal resistance from -80° C to +200° C
- Excellent ageing resistance
- High resistance to oil and grease

■ **EPDM**

- Very good compression set rating
- Good chemical resistance
- Good resistance to mineral oils and greases
- Continuous operating temperature up to +130° C

The advantages

- Optimum solution for fastening a load-bearing threaded insert to a thin-walled component
- The only reliable alternative for hollow components, housings and other components where access is only available from one side.
- Blind rivet technology replaces screw fasteners
- Vibration and noise decoupling
- Electrical and thermal insulation
- Tolerance adjustment – Stress relief
 - Stresses caused by manufacturing technology (on component to be fastened)
 - Thermal expansion
 - Dynamic fastener (e.g. moves with the vehicle)
- Easy-to-fit. Setting (bulge clamping) takes place during the screwing process
- Easy-to-dismantle
- Allows full design flexibility thanks to variable parameters

RIVKLE® steel

RIVKLE® stainless steel

RIVKLE® aluminium

RIVKLE® HRT

RIVKLE® PN
RIVKLE® Elastic

RIVKLE® blind rivet
studs, steel

Special designs

RIVKLE® Elastic – Blind rivet nuts for decoupling applications

Technical information

■ **Mating fasteners**

The RIVKLE® Elastic nut thread is manufactured to standard commercial tolerances (6H as per ISO 68-1). The thread is designed to accept a standard commercial mating fastener and will therefore accept any of the widely available screw fasteners with a 6g tolerance.

Rivet nuts can also be manufactured with American and British threads.

■ **Mechanical characteristics – Tightening torque M_A**

Size	Tightening torque M_A max. (Nm)
M 4	2.0
M 5	2.0
M 6	4.5
M 8	7.0

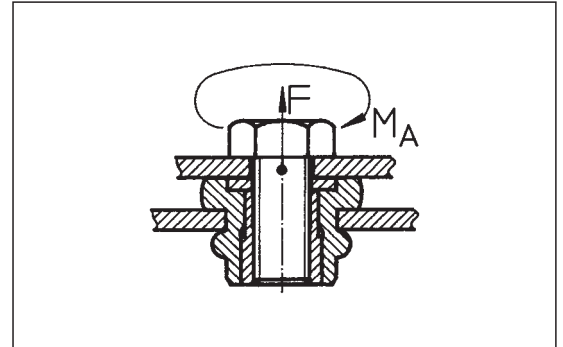

Test method to identify the torque of RIVKLE® Elastic with washer

■ **Mechanical characteristics – Axial test load F_A**

Size	Axial test load F_A (N)
M 4	150
M 5	150
M 6	250
M 8	400

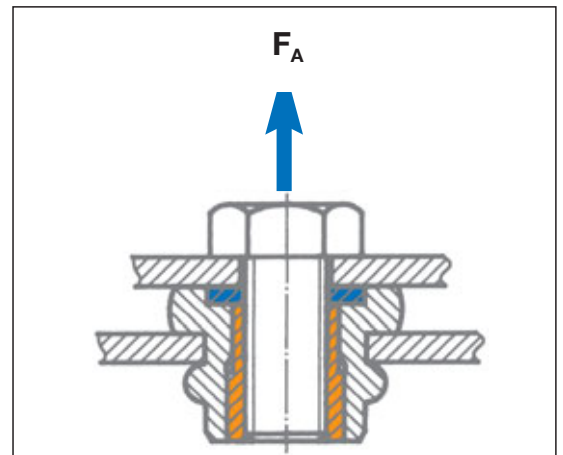

Test method to identify the axial test load

■ **Maximum clamping bulge deformation (w)**

Size	Max. clamping bulge deformation w (mm)
M 4	15.0
M 5	15.0
M 6	15.5
M 8	20.5

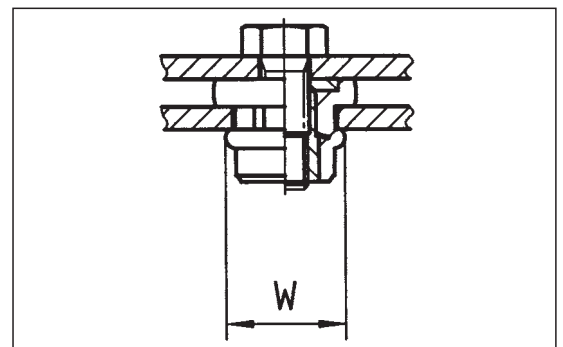

Measurement of the maximum clamping bulge deformation

RIVKLE® Elastic – Blind rivet nuts for decoupling applications

Versions

RIVKLE® Elastic with washer

Material TPE-V

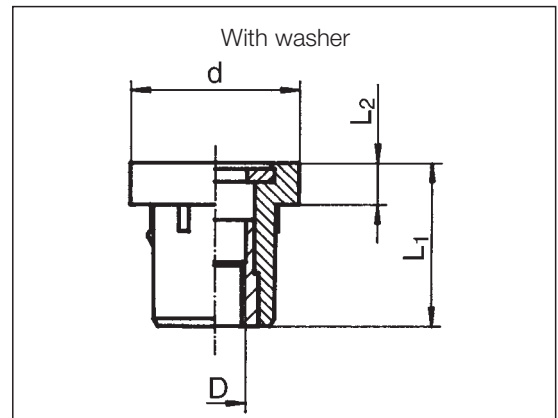

Product code	Type	D	d	L ₁	L ₂	Hole diameter D ₁	Set length L	Grip range
2431 004 0300	with washer	M 4	15	17.7	3.7	10.3 + 0.2	9	0.5 – 3.0
2431 005 0300	with washer	M 5	15	17.7	3.7	10.3 + 0.2	9	0.5 – 3.0
2431 006 0300	with washer	M 6	18	19.3	4.3	13.0 + 0.2	10	0.5 – 3.0
2431 008 0300	with washer	M 8	22	21.6	5.6	16.0 + 0.2	11	0.5 – 3.0

Standard: Body: TPE-V, 64 Shore A, black; insert: brass; washer: zinc-plated brass

RIVKLE® Elastic Special versions

Insert without thread

Product code	Type	D	d	L ₁	L ₂	Hole diameter D ₁	Set length L	Grip range
2431 362 0300	with washer	6.2	18	19.3	4.3	13.0 + 0.2	10.0	0.5 – 3.0

Body: TPE-V, 55 Shore A, black; insert: without thread

Material A2

Product code	Type	D	d	L ₁	L ₂	Hole diameter D ₁	Set length L	Grip range
2439 001 0601	with washer	M 6	18	19.3	4.3	13.0 + 0.2	10.0	0.5 – 3.0

Insert and washer material: A2

The values given above are correct to the best of our knowledge and are valid as typical standard values.

They are provided as a guide only and must not be used for specifications.

The standard value does not release users from their obligation to test products for their particular uses and production procedures.

RIVKLE® steel

RIVKLE® stainless steel

RIVKLE® aluminium

RIVKLE® HRT

RIVKLE® PN
RIVKLE® Elastic

RIVKLE® blind rivet
studs, steel

Special designs

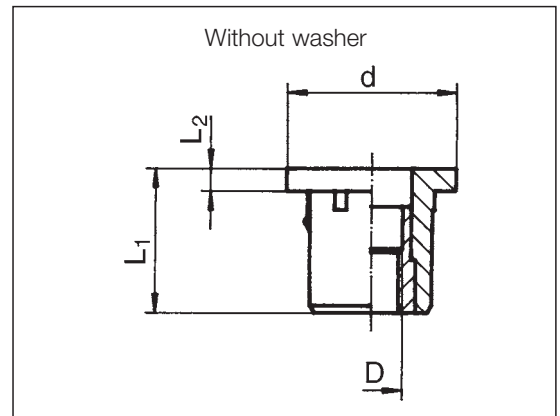
RIVKLE® Elastic – Blind rivet nuts for decoupling applications
Versions
RIVKLE® Elastic without washer
Material TPE-V

Product code	Type	D	d	L ₁	L ₂	Hole diameter D ₁	Set length L	Grip range
2430 004 0300	without washer	M 4	15	15.5	1.5	10.3 + 0.2	9	0.5 – 3.0
2430 005 0300	without washer	M 5	15	15.5	1.5	10.3 + 0.2	9	0.5 – 3.0
2430 006 0300	without washer	M 6	18	17.0	2.0	13.0 + 0.2	10	0.5 – 3.0
2430 008 0300	without washer	M 8	22	19.0	3.0	16.0 + 0.2	11	0.5 – 3.0

Standard: Body TPE-V, 64 Shore A, black; insert: brass

RIVKLE® Elastic Special versions
Elastomers

Product code	Type	D	d	L ₁	L ₂	Hole diameter D ₁	Set length L	Grip range
2430 206 0300	without washer	M 6	18	17.0	2.0	13.0 + 0.2	10.0	0.5 – 3.0

Body: VMQ, 70 ± 5 Shore A, black

The values given above are correct to the best of our knowledge and are valid as typical standard values.

They are provided as a guide only and must not be used for specifications.

The standard value does not release users from their obligation to test products for their particular uses and production procedures.

RIVKLE® Elastic HT

The answer's in the detail.

The new addition to the RIVKLE® Elastic product family – the RIVKLE® Elastic HT

The RIVKLE® Elastic was originally designed to secure a load-bearing threaded body to a thin-walled component with an additional noise and vibration decoupling property.

Special demands on this joint in terms of continuous operating temperature, tightening torque/loosening torque and tractive load/shear load led to the development of the RIVKLE® Elastic HT. A thermoplastic copolyester elastomer is used in this new decoupling blind rivet nut to meet the special requirements in combination with optimised component shapes.

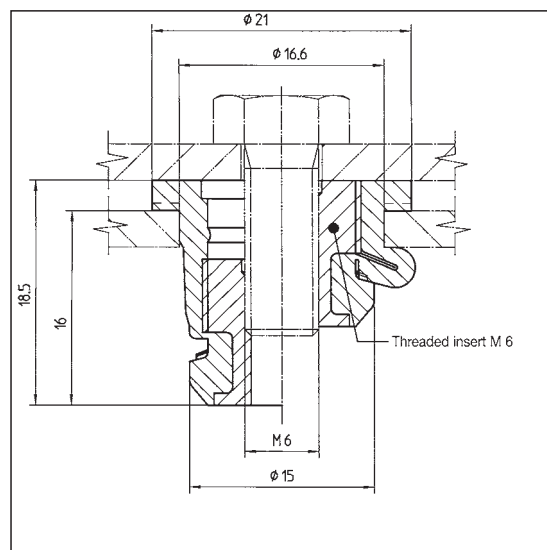

Advantages for the customer

- Screw connection up to property class 8.8 possible
- Continuous operating temperature up to +130° C
- Diesel oil resistant
- Damping behaviour in a temperature range of -40° C up to +130° C
- Improved tightening torques / loosening torques
- Improved tractive and shear load

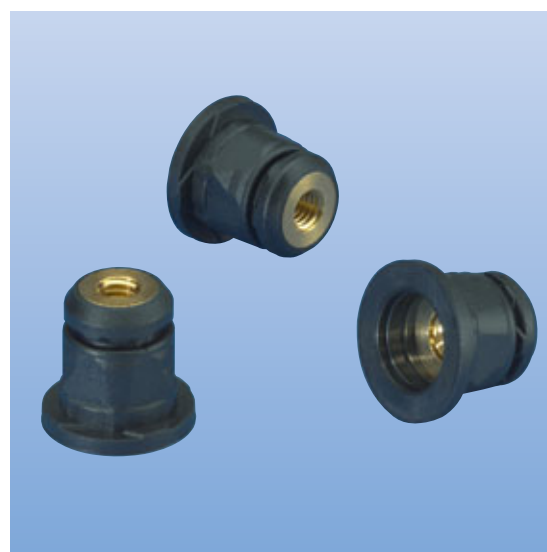

Wall thickness	Dimensions	Tightening torque*	Loosening torque*	Axial tractive load	Shear load
1.2 mm	M 6	M _A (max.) 9.5 Nm	M _L 7.0 Nm	F (max.) 260 N	F (max.) 250 N
3.0 mm	M 6	M _A (max.) 9.5 Nm	M _L 7.0 Nm	F (max.) 380 N	F (max.) 550 N

* Guideline values for screw connection with a screw from property class 8.8.
Measurement for mounting hole Ø (type M 6) 16.0 + 0.2 mm

Material TPC-EE

Product code	Type	D	d	L ₁	L ₂	Hole diameter D ₁	Set length L	Grip range
2432 006 0001	without washer	M 6	21	18.5	2.5	16.0 + 0.2	8.5	1 – 3

The values given above are correct to the best of our knowledge and are valid as typical standard values. They are provided as a guide only and must not be used for specifications. The standard value does not release users from their obligation to test products for their particular uses and production procedures.

RIVKLE® steel

RIVKLE® stainless steel

RIVKLE® aluminium

RIVKLE® HRT

RIVKLE® PN
RIVKLE® Elastic

RIVKLE® blind rivet studs, steel

Special designs

RIVKLE® Elastic – Blind rivet nuts for decoupling applications**Example applications – Automotive industry**

- Mounting for engine spoiler and side components BMW motor cycle
- Mounting for active carbon filter VW Beetle
- Compressor mounting Audi A6 allroad quattro

**Example applications – All industrial sectors**

- Heating and air-conditioning plant
- Electrical engineering and electronics:
Examples: fixing of printed circuit boards with electro-static isolation; mounting of sensitive measuring equipment; fixing of switchgear cabinets
- Agricultural machinery:
Examples: tractors, combine harvesters...
- Gardening power tools, lawn mowers...

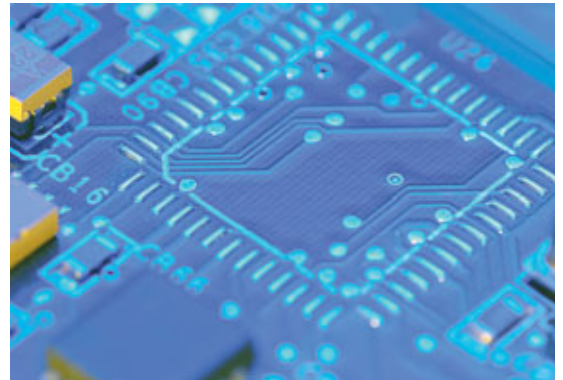

RIVKLE® Standard blind rivet studs

Advantages of RIVKLE® blind rivet studs

RIVKLE® blind rivet studs allow the supported component to be prepositioned on the supporting part. This is particularly useful for heavy or large components or where the mountings are hidden. These fastenings offer all the advantages of the other RIVKLE® ranges, i.e. ease and economy of installation, flexibility and environmental sustainability (see page 7).

Examples of applications

Refrigeration plant, ventilation systems, air conditioning equipment, securing panels and hoses to vehicle chassis, rails in switch cabinets, exhausts or electrical components in motor vehicles.

Type 3732 7

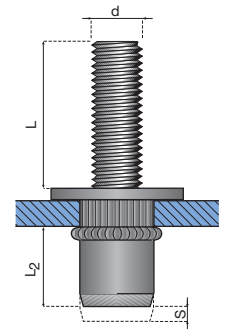
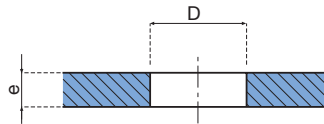
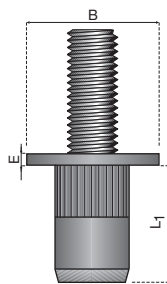

d	Thickness e	Hole D ^{+0.1/0}	B	E	S*	L	L ₁	L ₂ *	Product code
M5	0.5 – 3	7	10	1	S = 4.7-e	15	11	5.5	3732 705 0115
	0.5 – 3	7	10	1	S = 4.7-e	20	11	5.5	3732 705 0120
	0.5 – 3	7	10	1	S = 4.7-e	25	11	5.5	3732 705 0125
M6	0.5 – 3	9	13	1.5	S = 5.4-e	15	13	7.5	3732 706 0115
	0.5 – 3	9	13	1.5	S = 5.4-e	20	13	7.5	3732 706 0120
	0.5 – 3	9	13	1.5	S = 5.4-e	25	13	7.5	3732 706 0125
M8	0.5 – 3	11	16	1.5	S = 5.4-e	20	14	8.5	3732 708 0120
	0.5 – 3	11	16	1.5	S = 5.4-e	25	14	8.5	3732 708 0125

* Dimensions S and L₂ are indicative values. The difference in length S depends on the material thickness and is used as the setting tool stroke.

Dimensions in mm.

Surface treatment: 8µ zinc plated + passivated (Cr (VI) free according ROHS directives and scrapped cars directives). Other dimensions and variants can be supplied on request.

The setting process

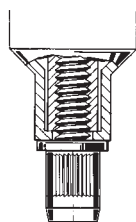

spin on

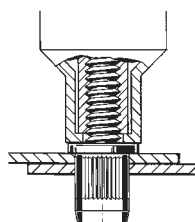

insert into the hole

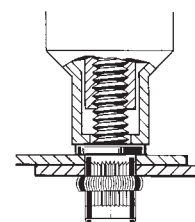

upset

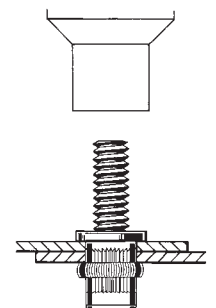

spin off

RIVKLE® steel

RIVKLE® stainless steel

RIVKLE® aluminium

RIVKLE® HRT

RIVKLE® PN
RIVKLE® Elastic

RIVKLE® blind rivet
studs, steel

Special designs

RIVKLE® Special designs of blind rivet studs

Even more uses are opened up by RIVKLE® blind rivet studs in specially designed product variants

On request, we can manufacture studs with the same options as the RIVKLE® blind rivet nuts (imperial threads, zinc-nickel surface treatments, stainless steel with special surface treatments, studs with special chamfer end geometry).

- RIVKLE® blind rivet stud, coarse thread for assembly of plastic components by pushing or tapping into place.



- RIVKLE® blind rivet stud, knurled, extra-small head. Very small or no head projection.



- RIVKLE® blind rivet stud, extra-large head to take higher mechanical loads.



- RIVKLE® blind rivet stud, hexagonal body and flat head for increased turning resistance.



Captive screw with spacer function

The screws are pre-fitted to speed up assembly.

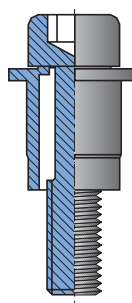

RIVKLE® Special designs of blind rivet nuts

As your partner in the development and manufacture of fastenings systems, we develop a large number of application-specific, purpose designed fasteners. Our work is carried out under the quality standards ISO 9001 and QS 9000. This chapter is intended only to give you a brief summary of what we can offer: additional functionality from the use of spray-on plastic parts, pre-assembled mechanically joined components, glued or welded parts etc.

Special designs of RIVKLE® blind rivet nuts

- **RIVKLE® with knurls on the body and under the extra-large head, this fastening provides improved mechanical properties in soft workpieces.**

Guarantees the best match of RIVKLE® blind rivet nuts to plastic workpieces. A zinc-nickel surface treatment provides optimum corrosion resistance.

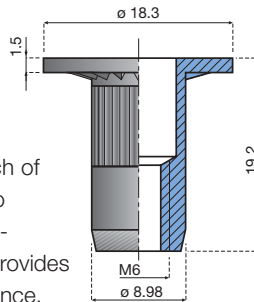

RIVKLE® steel

RIVKLE® stainless steel

RIVKLE® aluminium

- **RIVKLE® hexagonal body, UNF 7/16 thread**

For fastening motor vehicle safety belts, increased resistance to turning, very high mechanical loading capacity, a zinc-nickel surface treatment provides optimum corrosion resistance.

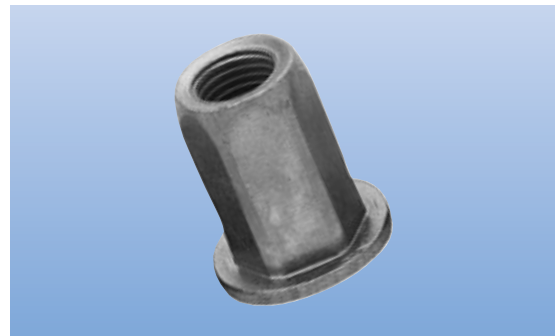

RIVKLE® HRT

- **RIVKLE® extra-large head, Ø 45 mm, for a large bearing area**

Ensures an even distribution of stresses in soft workpieces such as plastic. Black in colour for a pleasing appearance. The head is a captive press-on washer.



RIVKLE® PN
RIVKLE® Elastic

- **RIVKLE® blind rivet nut, round body,**

a threaded rivet sleeve, installed using a press, used as a spacer or pillar.

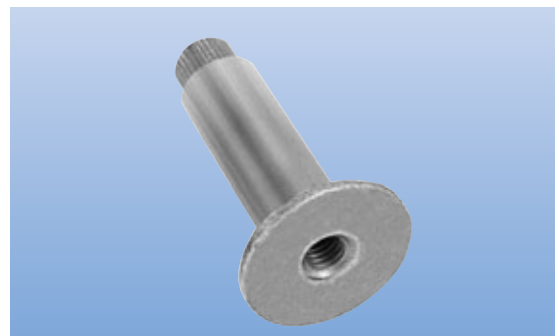
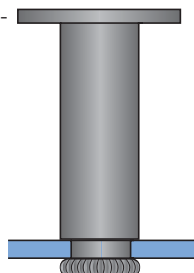

RIVKLE® blind rivet studs, steel

Special designs

RIVKLE® Special designs of blind rivet nuts

Special designs of RIVKLE® blind rivet nuts

■ **RIVKLE® sealing nut with moulded-on captive plastic seal**

Used on car boot hinges to provide a pressure-tight connection.



■ **RIVKLE® extra-thick head, installed as nut and spacer, in combination with a large chamfered end for easier assembly**

This RIVKLE® has a number of useful functions:

- rivets two components
- installs an internal thread
- centres the screw
- acts as a spacer.



■ **RIVKLE® oval head for installation in an appropriately shaped recess**

When installed in a plastic support with an oval recess, the head provides increased resistance to turning compared to the RIVKLE® blind rivet nut, without any head projection.

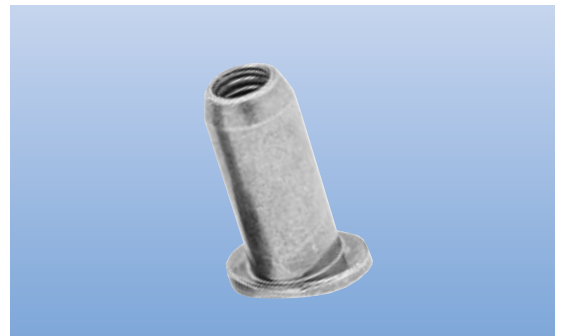

■ **RIVKLE® rivet nut, hexagonal body providing increased resistance to turning. It can act as a spacer and is very efficient when used in multiple assembly process using a press.**

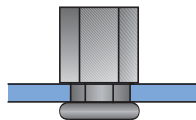

Further special designs

On request: imperial internal threads, zinc-nickel surface treatment, stainless steel with special surface treatments.

RIVKLE® Hand-operated setting tools for limited production volumes

Type S: Single-size hand-operated setting tool for RIVKLE® blind rivet nuts

- **Operation:**
Single-sized riveting tool with threaded drive. The RIVKLE® blind rivet nuts are spun on by hand. Setting is achieved using a crank and socket. (included as supplied).
- **Application:**
Occasional setting
- **Technical information:**
Output: up to 2 items/min., stroke: 6 mm
This tool is supplied with a nosepiece and mandrel.

Product code complete tool: 2353 01x x000
xx = 05 for M5, 06 for M6, 08 for M8, 10 for M10, 12 for M12



Material	M3	M4	M5	M6	M8	M10	M12	M14
Blind rivet nut								
Alu/steel/stainless								

We recommend the ZH 510, P 2005 or P 2007 tools for setting RIVKLE® blind rivet studs.

Z 305: Plier-type setting tool

- **Operation:**
The rivet is spun on and off using a knurled thumb nut. Setting is done by the lever effect of the pliers. Practical and quick stroke adjustment.
- **Application:**
Occasional setting
- **Technical information:**
Output: up to 4 items/min.

Product code basic tool*: 2351 010 0000
*Basic tool without mandrel and nosepiece



Material	M3	M4	M5	M6	M8	M10	M12	M14
Blind rivet nut								
Alu/steel/stainless								

We recommend the ZH 510, P 2005 or P 2007 tools for setting RIVKLE® blind rivet studs.



Mandrel blind rivet nuts



Nosepiece blind rivet nuts

Description	Blind rivet nut
	Product code
Mandrel	2351 01x x020
Nosepiece	2351 01x x030

xx = 03 for M3, 04 for M4, 05 for M5

RIVKLE® Hand-operated setting tools for limited and medium production volumes

ZH 510: Lever-type setting tool

- **Operation:**
The rivet is spun on and off the mandrel by an Archimedes screw feature.
Crimping by lever action.
Practical and quick stroke adjustment.
- **Application:**
Low production volumes
- **Technical information:**
Output: up to 5 items/min.

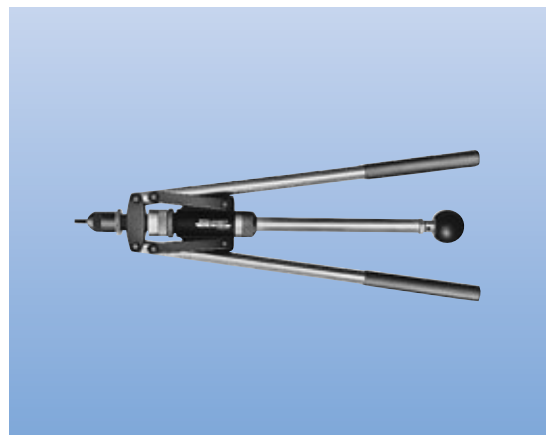

Mandrel blind rivet nuts



Nosepiece blind rivet nuts



Mandrel blind rivet studs



Nosepiece blind rivet studs

Product code basic tool*: 2351 030 0000

*Basic tool without mandrel and nosepiece

Description	Blind rivet nut Product code	Blind rivet stud Product code
Mandrel	2351 03x x020	3751 03x x020
Nosepiece	2351 03x x030	3751 03x x030

xx = 05 for M5, 06 for M6, 08 for M8, 10 for M10

Material	M3	M4	M5	M6	M8	M10	M12	M14
Blind rivet nut								
Aluminium			■	■	■	■		
Steel/stainl. steel			■	■	■			

Material	M3	M4	M5	M6	M8	M10	M12	M14
Blind rivet stud								
Steel			■	■	■			

E 308: Rechargeable setting tool

- **Operation:**
RIVKLE® Safely and simply spins RIVKLE® blind rivet nuts or studs on or off.
Constant setting speed.
Switches between setting and spinning automatically.
Tool-less quick-change mandrel system.
- **Application:**
Medium production volumes
- **Technical information:**
Drive 12 V DC motor, weight approx. 2.3 kg, output per charge 180 to 600 RIVKLE®, stroke 5.5 mm max., setting force 14500 N max.



Product code basic tool: 2361 080 0000

Adapter for RIVKLE® blind rivet nuts M4, M5 and M6 included with basic tool.

Description	Blind rivet nut Product code	Blind rivet stud Product code
Mandrel	2361 08x x020	3761 08x x020
Nosepiece	2361 08x x030	3761 08x x030

xx = 03 for M3, 04 for M4, 05 for M5, 06 for M6, 08 for M8, 10 for M10

Material	M3	M4	M5	M6	M8	M10	M12	M14
Blind rivet nut								
Aluminium	■	■	■	■	■	■		
Steel/stainl. steel	■	■	■	■	■			

Material	M3	M4	M5	M6	M8	M10	M12	M14
Blind rivet stud								
Steel		■	■	■	■			



Mandrel blind rivet nuts



Nosepiece blind rivet nuts



Mandrel blind rivet studs



Nosepiece blind rivet studs

RIVKLE® Hydraulic / pneumatic setting tools for medium and high production volumes

P 2005

- **Operation:** Automatic RIVKLE® loading by mandrel pressure, pneumatic/hydraulic setting, automatic spin-off. Stroke control. Mandrel changeover by bayonet lock.
- **Application:** High production volumes
- **Technical information:**
 Output: up to 15 items/min., weight: 2.6 kg, max. stroke: 7 mm, setting force: 21 000 N at 5.5 – 7 bar.
 This tool is delivered with equipment for RIVKLE® blind rivet nuts M 6.
 Maintenance and servicing tools on request.



Mandrel blind rivet nuts



Nosepiece blind rivet nuts



Mandrel blind rivet studs



Nosepiece blind rivet studs

Product code: 2361 550 6000

Description	Blind rivet nut	Blind rivet stud
	Product code	Product code
Mandrel	2361 13x x020	3761 13x x020
Nosepiece	2361 13x x030	3761 13x x030

xx = metric dimensions,
 Example: M6 = 06 for RIVKLE® M6.
 Except M12: Mandrel: 2361 531 2020,
 Nosepiece: 2361 531 2030
 Special changeover tool for P 2005 available on request!

Material	M3	M4	M5	M6	M8	M10	M12	M14
Blind rivet nut								
Alu	■	■	■	■	■	■	■	■
Steel	■	■	■	■	■	■	■	■
Stainl. steel	■	■	■	■	■	■	■	■

Material	M3	M4	M5	M6	M8	M10	M12	M14
Blind rivet stud								
Steel	■	■	■	■	■	■	■	■

P 2007

- **Operation:** One setting tool for variable material thicknesses of blind rivet nuts and studs, simple pulse to mount RIVKLE®, single trigger cycle, total consistency of setting by pressure force control, setting by color coding.
- **Application:** Medium to large production volume
- **Technical information:**
 Output: up to 15 items/min., weight: 2 kg, max. stroke: 7 mm, setting force: 20 000 N at 5.5 bar – 7 bar



Mandrel blind rivet nuts



Nosepiece blind rivet nuts



Mandrel blind rivet studs



Nosepiece blind rivet studs

Product code: 2361 560 1000

Description	Blind rivet nut product code	Blind rivet stud product code
Mandrel	2361 13x x020	3761 13x x020
Nosepiece	2361 13x x030	3761 13x x030

xx = metric dimensions,
 Example: M6 = 06 for RIVKLE® M6.
 Special changeover tool for P 2007 available on request!

Material	M3	M4	M5	M6	M8	M10	M12	M14
Blind rivet nut								
Alu/steel/stainless	■	■	■	■	■	■	■	■

Material	M3	M4	M5	M6	M8	M10	M12	M14
Blind rivet stud								
Steel	■	■	■	■	■	■	■	■

RIVKLE® Hydraulic / pneumatic setting tools for processing of RIVKLE® PN blind rivet nuts**P 2001 PN**

With the P 2001 PN setting tool, all types of blind rivet nuts from the RIVKLE® PN range can be mounted.

■ Operation:

Blind rivet spun on to the mandrel, pneumatic/hydraulic setting, trigger operated spin-off. Stroke limited by setting ring.

Mandrel changeover by bayonet lock.

■ Application: High production volumes.**■ Technical Information:**

Capability: up to 15 items/min., weight: 2.7 kg, max.

stroke: 15.5 mm, max. setting force: 15.000 N,

measurements: M 5 to M 8.

Product code: 2361 540 1000



If necessary, blind rivet nuts from the standard RIVKLE® range can be revited with the P 2001 PN as well.

RIVKLE® Setting machines

EPK C: Hydraulic-pneumatic tool with process control

- **Function:**
 Tool featuring pressure regulation and force monitor for 100% quality controlled riveting process, with fault warning signal. Automatic loading by mandrel pressure, automatic spin-off.
 Component-specific counting function.
 Also available with setting head in pistol or rod version. Multilingual touchscreen menu. Totally Operator-independent riveting process. (See also page 55).
- **Application:** High production volumes, high quality standards, safety components, fulfils statutory record keeping requirements.
- **Technical information:**
 Dimensions: M 3 to M 8, output: up to 20 items/min., pistol weight: 2.3 kg, stroke: max. 6.5 mm, setting force: max. 21 000 N.



Accessories for P 2005, P 2007 and EPK C

Description		Product code
Maintenance unit	G ¼" = 700 Ltr. at 6 bar	0196 000 1001
Balancer	Load capacity 2 – 5 kg	0196 000 1103
Supply hose	GC N NW 06/ldm	0196 000 1133
Hose clamp	8 – 12 mm	0196 000 1150

Hired tools on request – Service/Technical After-Sales +49 (0) 521/4482-851

SAC 310: Modular, semi-automatic setting head (spindle stroke principle, hydraulic pneumatic)

- **Function:**
 This light, compact setting head is designed for the semi-automatic setting of RIVKLE® blind rivet nuts and studs even on components that can only be accessed from one side. Automatic RIVKLE® loading by mandrel pressure, pneumatic/hydraulic setting, automatic spin-off. The system is designed in modules which means that either single-head or multi-head units can be built. Direct pneumatic and electronic control and process control are available. As an option, the unit can be fitted with a data output to enable compiling of quality documentation. A wide range of standard modules is available. Standard modules can be used to build stand-alone workstations or to incorporate a unit into a production line.
- **Application:** Medium to large series production volumes. Simultaneous setting of multiple RIVKLE® blind rivet nuts and studs.
- **Technical data:** Sizes: M 3 to M 10. Cycle time: approx. 2 seconds (setting and spin-off). Weight: 2 kg (M 6). Setting stroke: 7 mm (max)

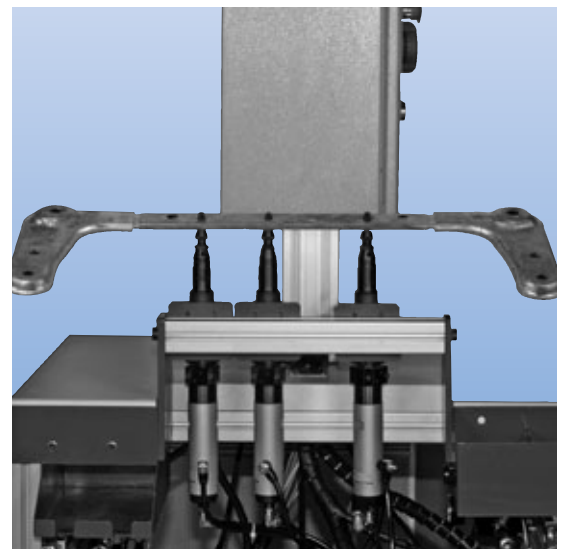

RIVKLE® Setting machines
***HSA 803: Automatic setting head
(Spindle stroke principle, hydraulic-pneumatic)***
■ Function:

This setting head automates the blind rivet nut and stud setting process, even with components that can only be accessed from one side. The RIVKLE® feed system features vibrating spiral conveyors or other feeder systems. With integrated process control. RIVKLE® blind rivet nuts and studs with hexagonal bodies can be easily fed and set in the right position the first time round. Loading and setting in any position, even overhead.

■ Application: High production volumes, high quality standards, safety components.

■ Technical information:

Dimensions: M 4 to M 10, loading time: approx. 2 seconds, riveting process: approx. 3 seconds, weight: approx. 15 kg.

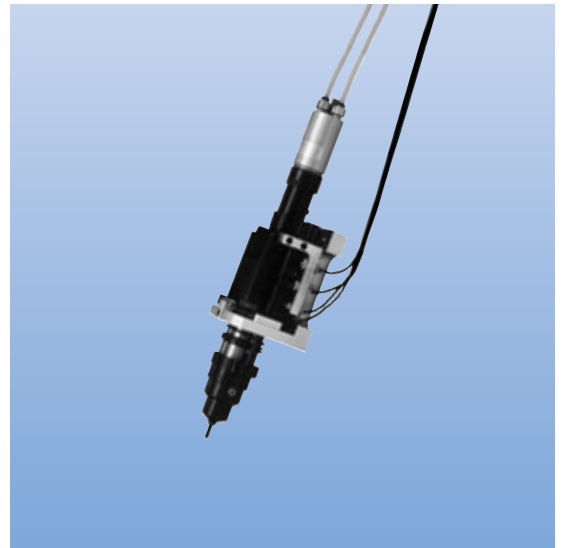

CFA 803: Automatic setting head (press principle)
■ Function:

For the automatic setting of blind rivet nuts and studs. The C-frame module can, for example, be integrated into an articulated robot as part of a complex manufacturing centre for components that can be accessed from both sides. Setting times of approx. 3.5 seconds are possible, thus providing extremely high productivity. RIVKLE® supply by way of RS ring sorter. The threaded mandrel is no longer required, thus eliminating downtime for the rotational replacement of this wearing part and preventing malfunctions. RIVKLE® blind rivet nuts and studs with hexagonal bodies can be easily fed and set in the right position the first time round. Loading and setting in any position, even overhead.

■ Application: High production volumes, high quality standards, safety components. Accesability from both sides.

■ Technical information:

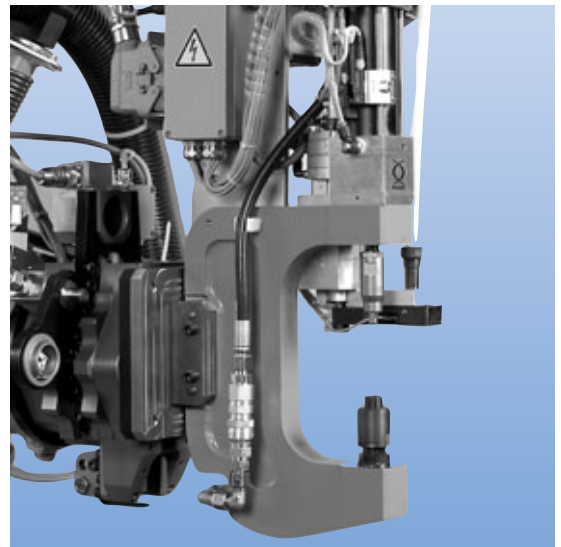
Dimensions: M 5 to M 8 (other dimensions on request), total cycle time: approx. 3.5 seconds/item, weight of C-frame module: approx. 25 kg (depends on size of C-frame), max. riveting force: 18 kN, max. operating pressure: 400 bar, PLC control.



Our applications engineering staff will be happy to help you select the right tool.

Progress in riveting through force-controlled setting!

EPK C

100 % process reliability

thanks to:

- 100 % control of all relevant parameters
- Automatic filtering of faulty components
- Automatic control of component clamping
- Computer aided documentation
- Plaintext error messages

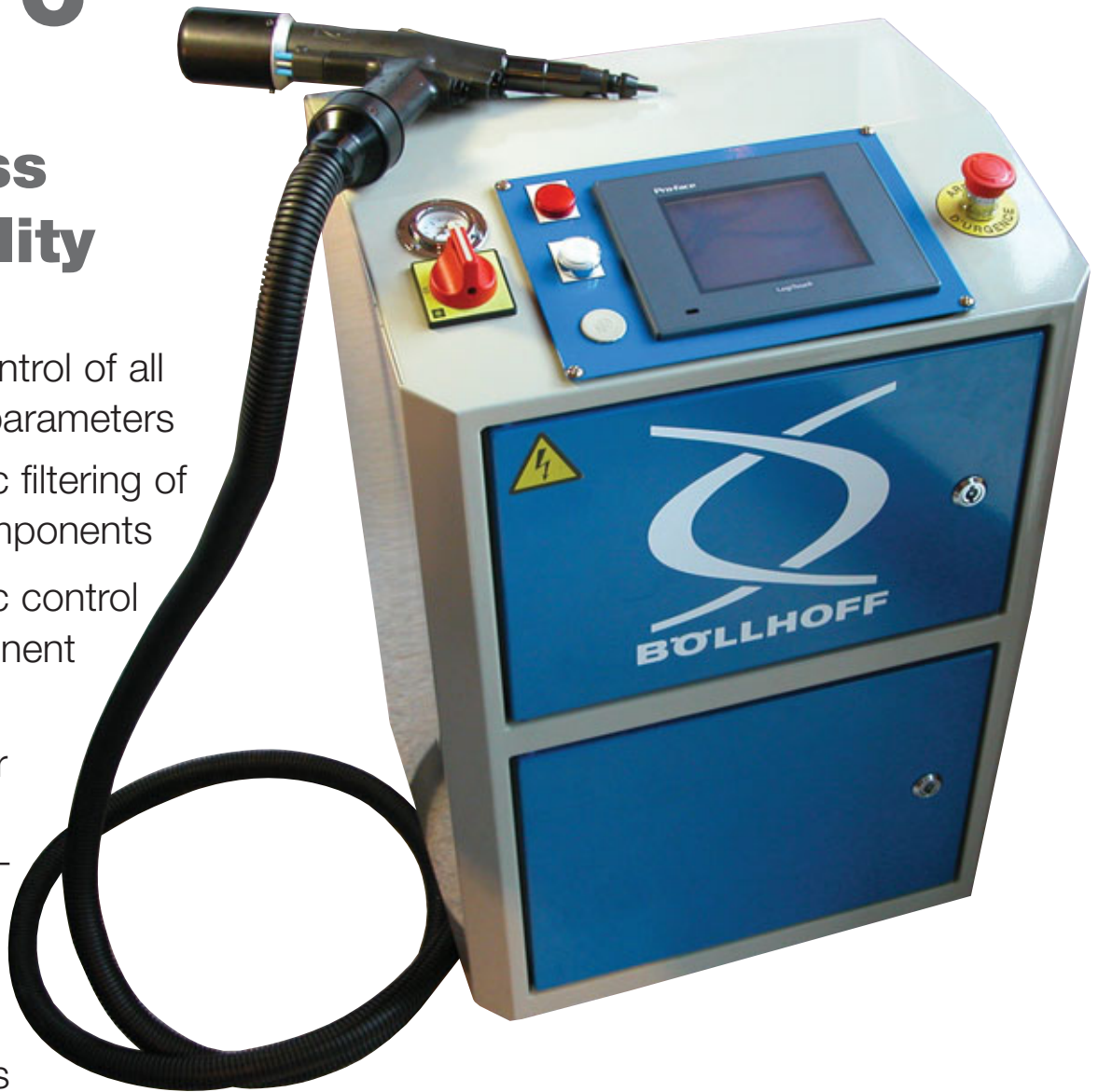

Advantages:

- Operator independent process
- No post production process costs
- No deformation of customer's component
- No damage to RIVKLE® thread
- Computer aided documentation
- Ergonomic setting head available as a pistol or rod
- Long service life of mandrels
- Compatible with previous model
- Touchscreen operation
- Multilingual menu
- Selected functions are password protected
- Optimised ergonomics (weights, dimensions etc.)
- Reduced noise emissions
- Easy setup thanks to menu guide
- Automatic control of component clamping.

Böllhoff International with companies in:

Argentina
Austria
Brazil
Canada
China
Czech Republic
France
Germany
Hungary
India
Italy
Japan
Mexico
Poland
Romania
Russia
Slovakia
South Africa
Spain
Turkey
United Kingdom
USA

Apart from these 22 countries, Böllhoff supports its international customers in other important industrial markets in close partnership with agents and dealers.

Subject to technical change.
Reprinting, even in extract form, only permitted with express consent.
Observe protective note according to DIN 34.

Böllhoff Verbindungstechnik GmbH
Archimedesstraße 1-4 · 33649 Bielefeld · Germany
Phone +49 (0)521 / 4482-05 (326) · Fax +49 (0)521 / 4482 - 658
www.boellhoff.com · fasteningtechnology@boellhoff.com

